

TRAVELSMITH®

VENDOR PARTNERSHIP MANUAL

NEW CORPORATE OFFICE

773 SAN MARIN DRIVE, SUITE 2300

NOVATO, CA 94945

415-798-3000

WWW.TRAVELSMITH.COM

UPDATED APRIL 8, 2010

THIS MANUAL SUPERSEDES ALL PREVIOUSLY ISSUED VERSIONS
AND IS EFFECTIVE IMMEDIATELY.

I. INTRODUCTION

VENDOR PARTNERSHIP MANUAL AGREEMENT.....4

II. SAMPLES

FIT & PRODUCT DEVELOPMENT5
CATALOG PHOTOGRAPHY.....5
TOP-OF-PRODUCTION (TOP)5

III. MANUFACTURING

TRIM CARD6
PRODUCT SPECIFICATIONS STANDARDS.....7
QUALITY ASSURANCE7
CLASSIFICATION OF DEFECTS.....7
INSPECTION FAILURE CRITERIA.....10
MEASUREMENT GUIDELINES13
FABRIC AND GARMENT TESTING23
CONSUMER PRODUCT SAFETY IMPROVEMENT ACT.....24
PRODUCT LABELS26
LABEL PLACEMENT27

IV. PACKAGING AND PACKAGE LABELS

ITEM PACKAGING & LABELING28
CASE ATTRIBUTE REQUIREMENTS31
CASE PACKING.....32
CASE SEALING/PALLETIZING.....33

V. FULFILLMENT

DOMESTIC VENDOR ROUTING GUIDE.....34
BOL.....35
IMPORT REQUIREMENTS.....36
INT'L VENDOR ROUTING UIDE37
ADVANCE SHIPMENT NOTICE (ASN)38
EDI/ VENDOR NET STANDARDS.....38
PACKING SLIPS41
EXTERNAL CASE LABELING.....42

VI. PRODUCT SAFETY.....45

VII. COMPLIANCE

TERMS AND CONDITIONS OF PURCHASE.....46
CHARGEBACK POLICY51
RETURN TO VENDOR POLICY.....53
VENDOR PARTNERSHIP SOCIAL RESPONSIBILITY GUIDELINES53

VIII. APPENDIX

DEFINITIONS54

I. INTRODUCTION

TravelSmith is focused on expanding our business in a healthy and profitable manner. We are committed to providing our customers with outstanding customer service, our investors with superior returns, and our employees with a productive, rewarding environment. We are further committed to the responsibilities of corporate ethics in both the local and wider communities in which we do business.

Our vendors are important stakeholders in the success of our business and we wish to build a mutually profitable partnership. This vendor manual will provide you with an overview of our Company policies and procedures. We want to provide a very clear set of expectations for our vendor partnership, and this manual is designed as a guidebook for those expectations.

TravelSmith is committed to satisfying our customers. Our products are *GUARANTEED 100%. NO QUESTIONS. NO EXCEPTIONS.* We promise a full refund if a customer is not *totally satisfied at any time* with a TravelSmith product.

VENDOR PARTNERSHIP MANUAL AGREEMENT

CONFIRMATION OF RECEIPT

This form states that you understand all the standards and requirements outlined in the Vendor Partnership Manual. By signing and returning this form, you confirm that you have received and understand the TravelSmith Vendor Partnership Guidelines and agree to comply with all the standards and business practices as listed. Please sign, date and return this form to the TravelSmith Vendor Compliance Department. If you are unclear with any portion of the manual, please contact us at (415) 798-3027. By agreeing to do business with TravelSmith, vendors are held to the standards in this manual and are subject to non-compliance charges incurred by TravelSmith.

If TravelSmith discovers the undersigned vendor has violated any of the Vendor Partnership Guidelines, TravelSmith may choose to cancel any outstanding orders, terminate the business relationship, and/or possibly pursue legal action.

The most recent updates to this vendor manual, as well as many helpful forms and instructions, can always be accessed online at <http://ccsginc.com>. If you don't already have one, you will be able to request a username and password from the home page

TRAVELSMITH[®]

FAX COVER SHEET

TO: JEN MCAFEE
FAX: (414) 921-5140
PAGES: 1

FROM VENDOR: _____
VENDOR CONTACT NAME: _____
CONTACT EMAIL: _____
CONTACT PHONE: _____
CONTACT FAX: _____
CONTACT ADDRESS: _____

RE: TravelSmith Vendor Partnership Manual

TravelSmith is focused on expanding our business in a healthy and profitable manner. We are committed to providing our customers with outstanding customer service. We are further committed to the responsibilities of corporate efforts in both the local and wider communities in which we do business. Our vendors are important stakeholders in the success of our business and we wish to build a mutually profitable partnership. We require that our vendors assure that our standards will be met as outlined in the Vendor Partnership Manual. We want to provide a very clear set of expectations for our vendors, if you have questions regarding any portion of the Vendor Partnership Manual, please contact the Vendor Compliance Manager at (415) 798-3027.

As an authorized representative, the undersigned agrees to the terms and conditions of the Vendor Partnership Manual.

Name: _____

Signature: _____

Title: _____

Company: _____

Date: _____

II. SAMPLES

At TravelSmith we require a variety of samples throughout our development process. Each sample has a specific purpose and is outlined below. Please work with your TravelSmith contact to obtain necessary information and timing of each sample. All sampling costs are the vendor's responsibility.

FIT & PRODUCT DEVELOPMENT

Fit & Product Development samples are requested from the inception of the design through final approval. These samples are used to perfect the details and fit of a product. A completed TravelSmith sample card must be attached to the left (wearer's side) underarm seam or waistband.

CATALOG PHOTOGRAPHY

Photography samples are required for all products introduced into the line. Photography samples should meet all design, color, fabric, trim, finding, fit and labeling specifications. If a product is to be marked with "SAMPLE", it should be done in an inconspicuous location. One photo sample in each colorway offered, in our sample size, is required. Samples must be received on or before the deadline assigned by your TravelSmith contact. A 12" x 12" fabric swatch (of each colorway), and trim card (template on following page) must be included w/ the samples. Please see page 6 of the manual for a copy of the trim card. Photo sample costs are the vendor's responsibility.

TOP-OF-PRODUCTION (TOP)

APPAREL

Two (2) TOP samples are required for all apparel. TOP samples are to be received within two (2) weeks of cutting the first bulk production. TOP samples are to be representative of the bulk cutting, sewing and packaging.

Accuracy is very important. The samples will be used when accepting goods into stock (any discrepancies could result in delays at the warehouse). A product produced in a sample room or facility other than where production is made is not acceptable.

If the samples do not meet specification and quality standards, the Technical Designer or Merchandising Representative will advise corrections to be made to bulk production. Merchandise received at the distribution center that does not meet specification and quality standards are subject to 100% inspection or return to vendor at the expense of the vendor.

Two samples, plus 6x6" color swatches for additional colors, are to be submitted to the Merchandising Department, with the exception of Women's Plus Size samples. In this case, only one (1) sample, plus color swatches are required. Upon approval, one Missy/Men's sample will be forwarded to the distribution center for use in quality inspections and the other will be kept by Merchandising for reference. The Women's Plus Size sample will be forwarded to the distribution center. The samples must conform to all fit, quality, packaging and labeling standards. TOP sample costs are the vendor's responsibility.

If TOPs are not received prior to PO delivery at the DC, a chargeback will be assessed to the vendor.

OTHER CATAGORIES

For off-line apparel buys, follow the rules above; we need 2 TOPs and 1 photography sample. Also, a soft copy spec sent to the technical designer or merchant is required concurrent or prior to the receipt of the TOP sample.

For hard goods, accessory and footwear items, please work with your merchant on what samples or information is needed.

TRAVELSMITH TRIM CARD

SEASON:
STYLE #
DESCRIPTION:

VENDOR:
DESCRIPTION:
COLORS:

DATE:

SHELL FABRIC:

LINING/POCKETING/ INTERLINING:

--	--

SUPPLIER:	SUPPLIER:
CODE #	CODE #
COLORWAYS:	COLORWAYS:
FABRIC CONTENT/CONSTRUCTION/WEIGHT:	FABRIC CONTENT/CONSTRUCTION/WEIGHT:

MAIN/CARE CONTENT/ COUNTRY OF ORIGIN/PO LABELS:

BUTTONS AND MISC. TRIMS:

--	--

SUPPLIER:
CODE #
SIZE:

POLYBAG GUMSTICKER:

THREAD

--	--

ZIPPER & PULL

--

SUPPLIER:
CODE #
SIZE:

*FOR ADDITIONAL TRIMS PLEASE USE SEPARATE PAGE

III. MANUFACTURING

PRODUCT SPECIFICATIONS STANDARDS

TravelSmith's goal is to provide the highest quality product and service for our customers. The vendor is responsible for maintaining complete and accurate records of the in-line, end-of-line quality inspections and final packaged product audits. Audits should be performed using a 4.0% AQL.

The factory must inspect fabric prior to cutting to ensure that only first quality material is utilized in production. If there is any question about acceptability, send production yardage to your Merchandising Representative for review. Accurate and complete inspection records must be maintained and available to a TravelSmith Representative upon request.

QUALITY ASSURANCE

All merchandise is inspected using a 4% AQL military sampling plan upon receipt at the TravelSmith distribution center for conformance to quality, measurement, and packaging and labeling specifications. The sampling plan may be increased or decreased depending upon the vendor's history of overall product quality. If the product passes these criteria, the entire shipment is accepted. If the product fails the inspection, the entire shipment is put on hold.

The disposition of a shipment placed on hold is made based on discussions with the Merchandising and Inventory Planning team members. The vendor is notified of the problem and whether the shipment will be returned to the vendor or is to be 100% inspected. In either case, charges will be assessed to the vendor for operating costs incurred in resolving the problems. For more information on chargeback and return to vendor policies, see Section VII - Compliance.

CLASSIFICATION OF DEFECTS

Defects occur in varying degrees. Minor defects are acceptable; Major or Critical defects are rejected. Defect acceptability is based on the effect the damaged product will have on the customer. Price, end use, materials and construction of a product dictate different levels of acceptance by the TravelSmith customer. Defects are classified as follows:

1. Minor Defect

the product serviceability or wearability is not affected. If noticed by the customer, would not cause any objection. The defect will not affect the comfort or fit of the product.

2. Major Defect

a product would be rendered unusable. The defect would adversely affect the serviceability of the product or shorten the life of the product. The defect would be obvious to the customer and would result in a return.

3. Critical Defect

the product would definitely be unusable, or would require early repair or replacement. The defect will cause a product to be uncomfortable, not fit or may cause an injury to the consumer. A product with a critical defect would most assuredly result in a return.

PRODUCT ZONES

The position of a construction defect or flaw may determine the acceptance or rejection of a product. The area on a product and the visibility to the customer defines zones. Each product has specific zones that are more important than others and guidelines are defined accordingly.

ZONE 1

Areas of a product with extremely high visibility and are likely to be viewed from a close distance at the time of purchase or receipt. Minor flaws in this area may be classified as Major and would be cause for rejection of the product.

ZONE 2

Areas of the product that are not visibly dominant, but are seen in normal use. Minor flaws in this area would be evaluated based upon size, color and intended use of the product to determine acceptability.

ZONE 3

An area of the product not seen in normal everyday use. Minor or cosmetic flaws are more acceptable here than in any other area of the product. Flaws will be evaluated by product and intended end use.

Dress Zone Chart

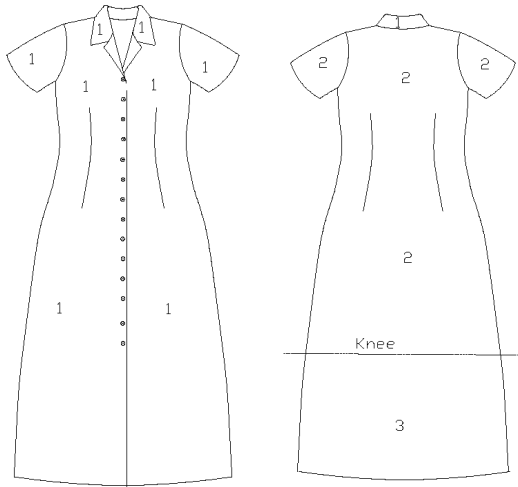

Sweater Zone Chart

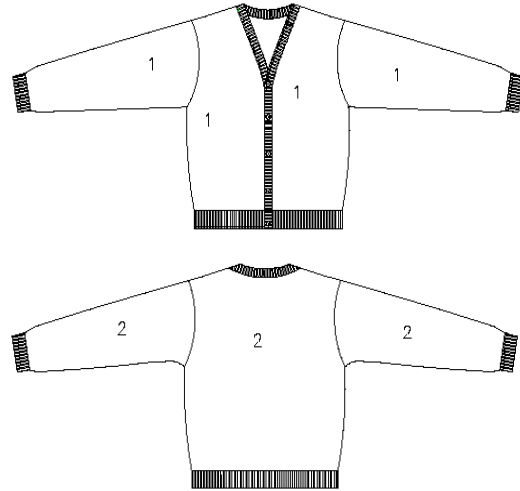

Shirt Zone Chart
Skirt Zone Chart

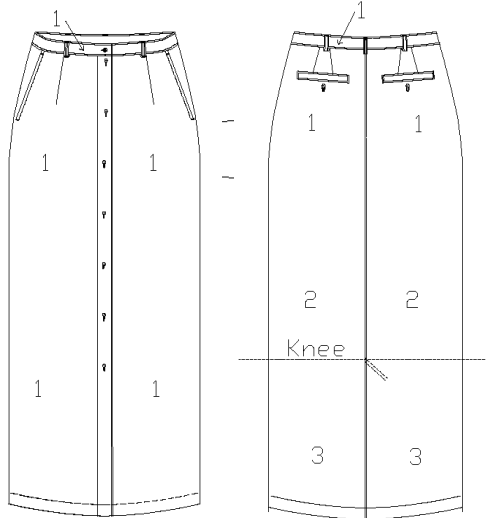
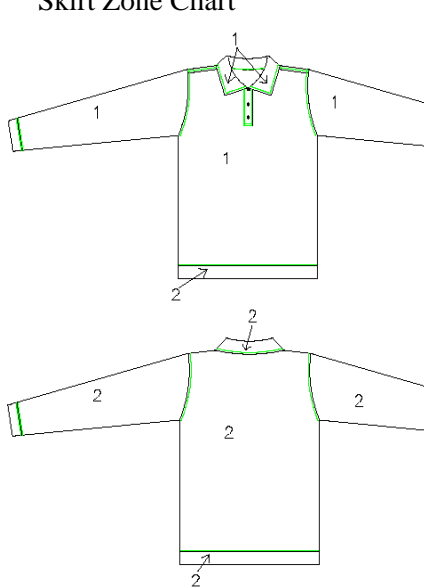

Outerwear Zone Chart

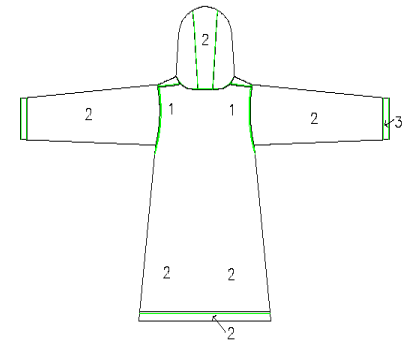

Pants Zone Chart

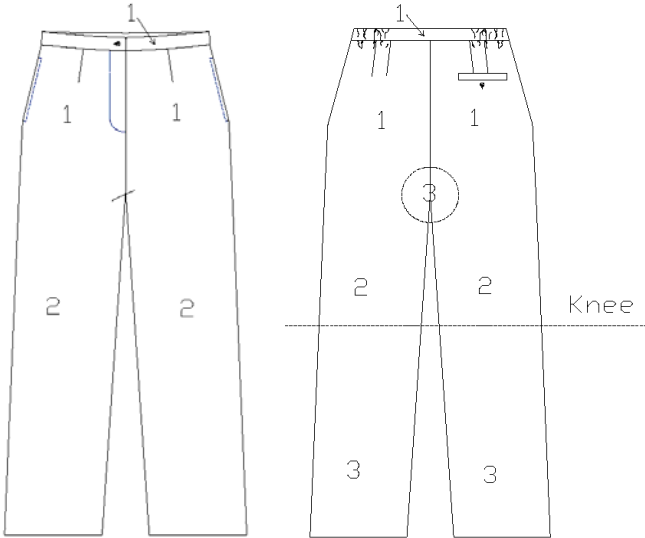

INSPECTION FAILURE CRITERIA

FABRIC DEFECTS

- Any hole or blemish
- Snagged or pulled threads or yarns
- Foreign matter in the fabric
- Heavy barre or machine lines
- Uneven dyeing or printing
- Slubs, runs and misweaves, as defined by TravelSmith
- Poor hand, i.e., stiff
- Seam Slippage

CONSTRUCTION DEFECTS

STITCHING AND SEAMS

- Broken, uneven or skipped stitches
- Excessively tight or loose tension
- Needle cuts
- Crooked, puckered, curled wavy or uneven seams
- Open seams
- Uneven topstitching
- Use of monofilament thread, unless approved
- Seam allowance too narrow in areas of stress, e.g., sleeve or front placket, causing garment to tear.

BUTTONS, BUTTONHOLES & FINDINGS

- Component not aligned
- Buttons not securely sewn
- Defective or malfunctioning part
- Component color not as specified
- Poorly made buttonholes; not cut open, too small or too large
- Loose threads

POCKETS

- Uneven in size, shape or location
- Flap incorrect shape
- Sewn in puckers or pleats

LABELS

- Incorrect labels
- Labels not positioned as specified
- Incorrect information
- Handwritten, illegible, incomplete or missing

PRESSING

- Burn, scorch or other mark on surface of garment
- Excessively wrinkled garments, unless specified

HEMS

- Puckered or twisted

- Uneven hem width

THREADS & YARNS

- Excessive and / or loose threads
- Thread other than specified color, size or type

DIMENSIONS

- Corresponding parts should be symmetrical and measure the same unless otherwise specified
- Measurement specifications outside of specified tolerance

REPAIRS

- Poorly mended, noticeable repair
- Loose threads from repair

CONSTRUCTION

- Foreign objects sewn into garment
- Parts sewn on incorrectly
- Raw edges or untrimmed edges, unless specified
- Incorrect or missing bar tack

BELT LOOPS/WAISTBANDS

- Raw edges on belt loop
- Missing, crooked, incorrectly placed or wrong number of belt loops
- Uneven waistband width (+/- 1/8", but not both)
- Waistbands that have excessive puckering, twisting, turn-back or fullness

COLLAR/NECK

- Collar points improperly shaped or not uniform (+/- 1/8")
- Collar band or under collar showing above top collar
- Neck opening off-center
- Neck puckered or stretched

MATCHING

- Uneven stripe alignment (front must be straight)
- Plaids, checks, stripes not matching at center front or other specified location
- Pockets/plackets not matched to body as specified

PLACKETS

- Crooked more than 1/4" from top to bottom
- Length not as specified (+/- 1/4")
- Sewn off-grain
- Distorted or uneven width

GENERAL DEFECTS

- Soilage-oil marks, spots, ink, rings left after cleaning soil
- Any measurement not as specified or out of tolerance
- Any item not conforming to construction specifications
- Substitute or missing parts, unless pre-approved by TravelSmith

- Shaded parts
- Marked “seconds”
- Color off standard-must be within acceptable shade bands when available

MEASUREMENT GUIDELINES

All apparel must be measured in the following manner unless otherwise stated on the specification package. All measurements are to be taken with the garments laid on a flat surface. The garment should be in a natural position, free of tension and with wrinkles smoothed out. Measure wearer's left side (i.e. sleeve, armhole, thigh, inseam).

All measurements should be taken with a standard plastic or metal tape measure. Periodically, the tape measure must be checked against a metal ruler for accuracy.

Please note:

- All buttons and zippers must be completely closed
- Button spacing is measured center of button to center of button
- Extended measurements should be the minimum stretched measurement. Fully extend the fabric until it lays flat. The fabric should not be distorted, nor should the elastic be extended to its full dimension.
- Belt loops are measured at center of loop
- Measure from center of seam for felled seams and edge of seam for safety stitch or single needle joined seams.

1. ACROSS FRONT (HIGH CHEST)

- With buttons and zippers closed, measure straight across from armhole seam to armhole seam. Specify the distance down from the high point shoulder for the standard size on the spec.

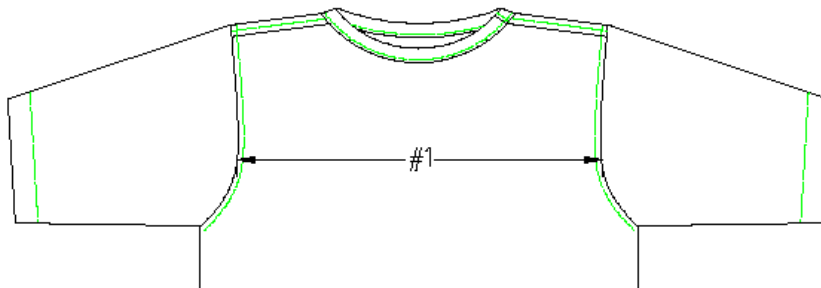

2. ACROSS SHOULDER

- Lay garment flat with back facing you and measure straight across from LPS (low point shoulder) to LPS.
- Measure straight across back from point to point.

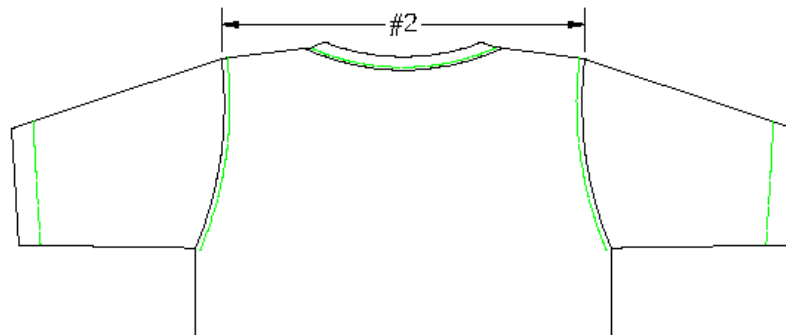

3. ACROSS BACK

- With buttons and zippers closed, measure straight across from armhole seam to armhole seam. Specify the distance down from the high point shoulder for the standard size on the spec.

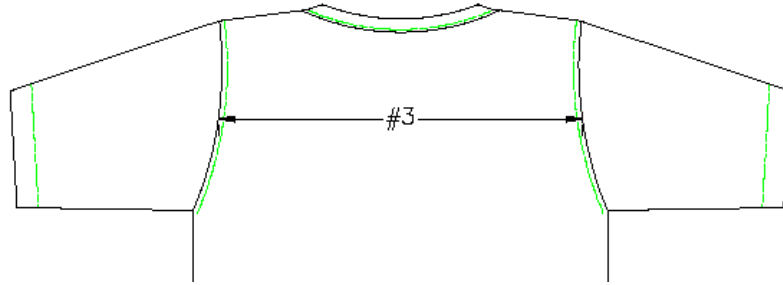

4. **CHEST/BUST***

- With the front of the garment facing you, measure straight across body 1” down from armhole seam.

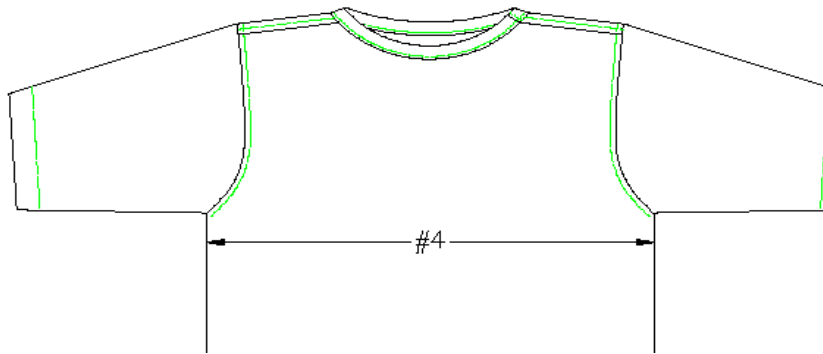

5. **WAIST***

A. RELAXED

- Measure along the center of the waistband. Top edge of front and back waistbands must be even. All closures must be fastened and button must be at the end of the buttonhole.

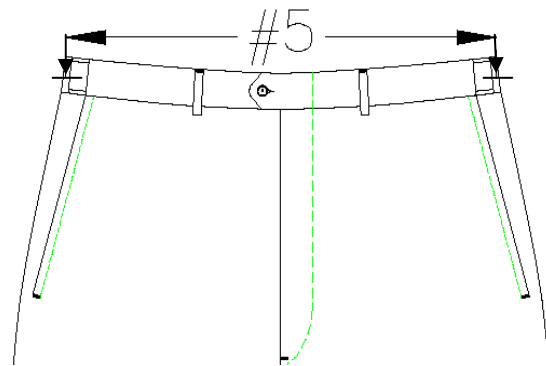

B. EXTENDED

- Stretch elastic waist to release all gathers in garment. Do not overextend. Insert measuring tape into top of waistband (no more than 1/2”) and measure across the top of the opening.

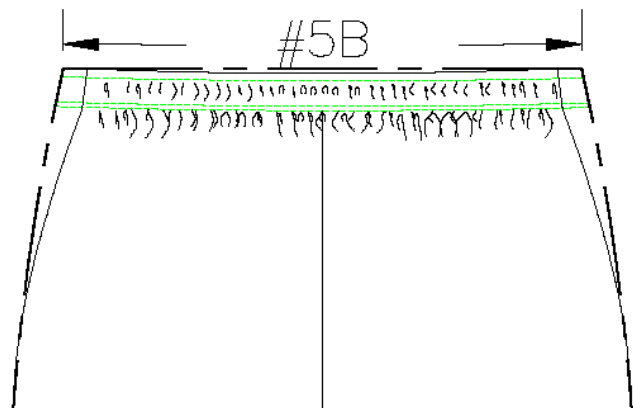

6. HIGH HIP (3 POINT MEASUREMENT)*

- Lay garment flat with front facing you.
- Measure down from BWB (bottom of waistband) at center front and side seams. Measuring from side to side you should form a slight “V” shape on the garment.
- Specify the distance down from BWB (bottom of waistband) to each point for the standard size on the spec.

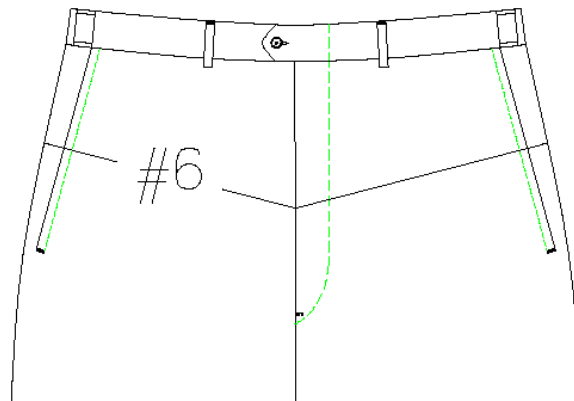

7. LOW HIP/SEAT (3 POINT MEASUREMENT)*

- Lay garment flat with front facing you.
- Measure down from BWB (bottom of waistband) at center front and side seams. Measuring from side to side you should form a slight “V” shape on the garment.
- Specify the distance down from BWB (bottom of waistband) to each point for the standard size on the spec.

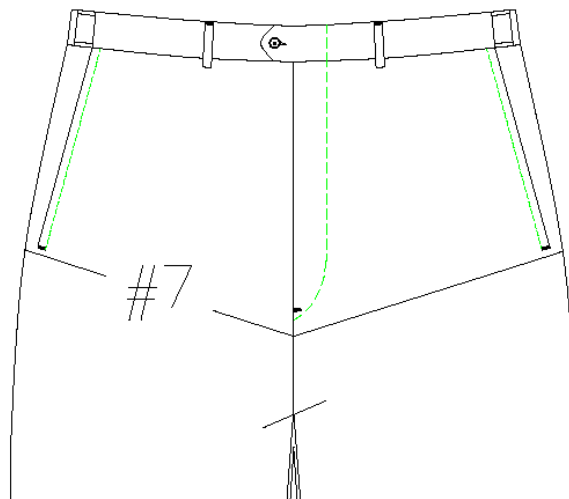

8. SWEEP*

- Measure along the bottom edge of garment, from side seam to side seam. If garment has side slits or shirrtail, measure straight across the top of the slits or shirrtail.

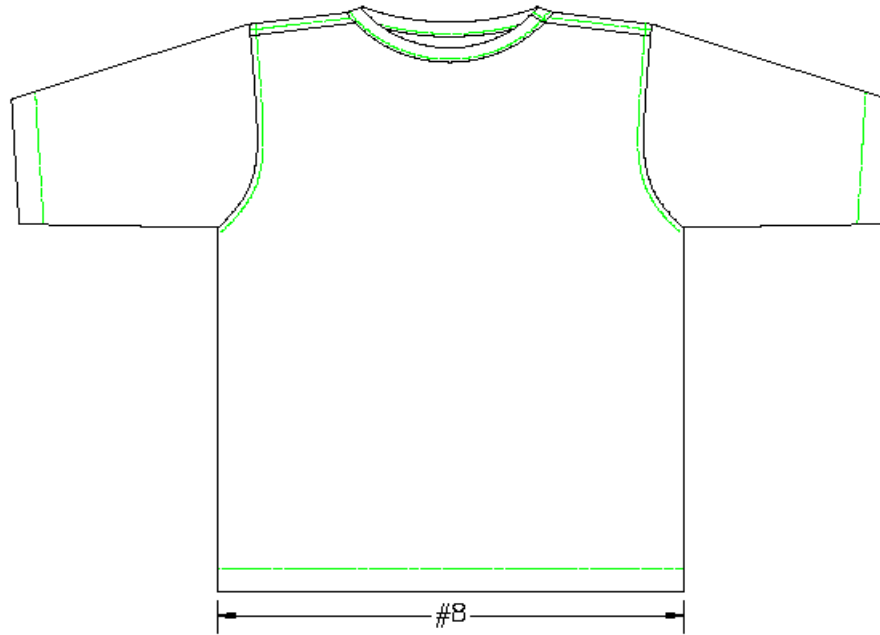

9. THIGH*

Lay one leg flat. Measure across garment 1" below crotch point, keeping the tape measure parallel to hem.

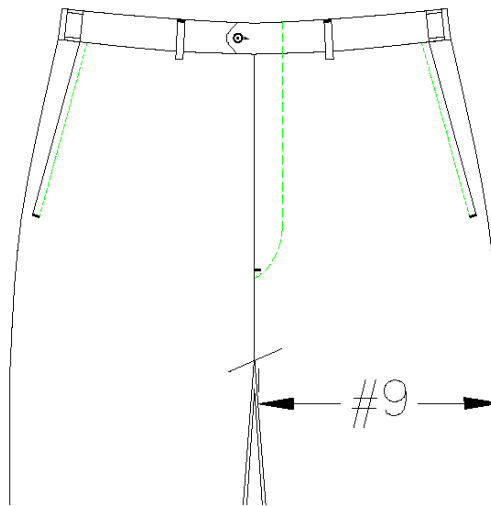

10. KNEE*

- Lay one leg flat.
- Measure down pant inseam 12½" for women's, 12" for women's petite, and 15" for men's.
- Measure straight across the leg from fold to fold keeping tape measure parallel to hem.

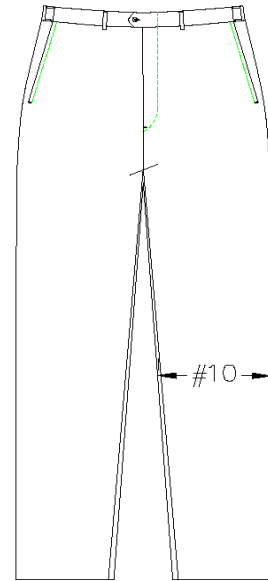

11. LEG OPENING*

- Lay one leg flat.
- Measure straight across bottom opening from fold to fold.

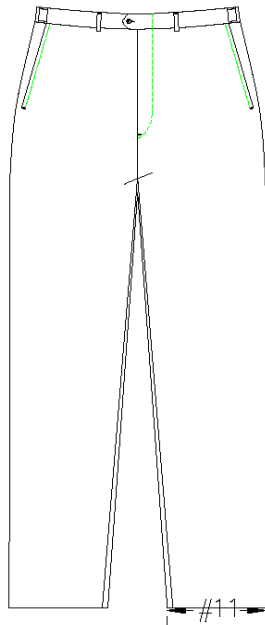

12. INSEAM

- Lay one leg flat.
- Measure from crotch point down leg (along seam) to bottom of the leg opening.

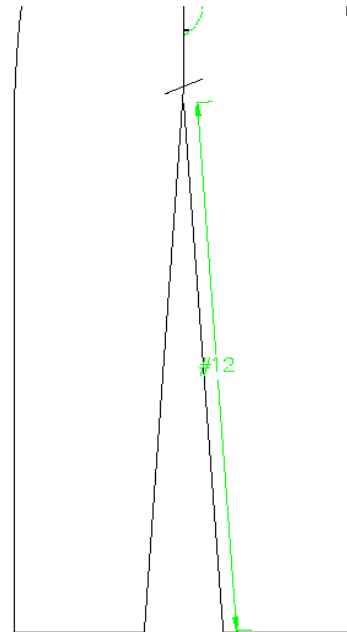

13. FRONT RISE

- Lay garment flat with front facing you.
- Measure from BWB to crotch seam, following the shape of the front rise.

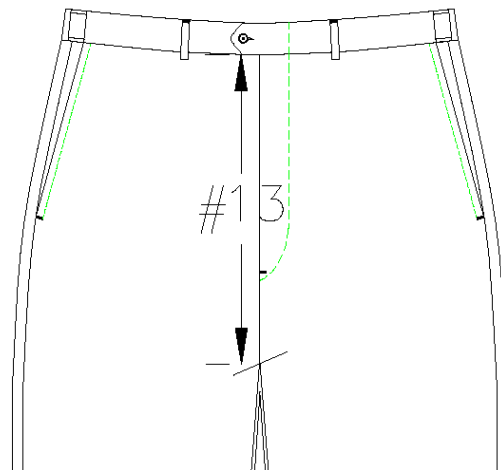

14. BACK RISE

- Lay garment flat with back facing you.
- Measure from BWB to crotch seam, following the shape of the rise seam.

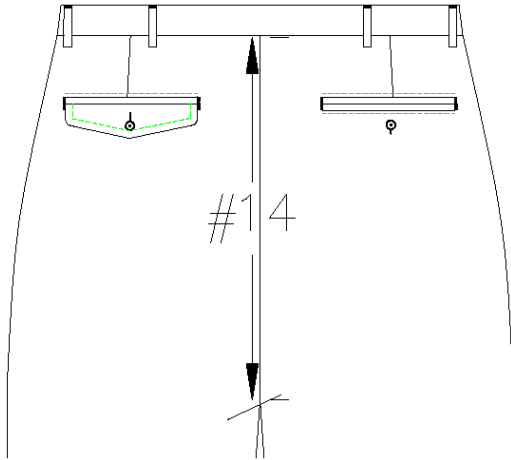

15. ARMHOLE STRAIGHT

- Measure straight from LPS to underarm seam.

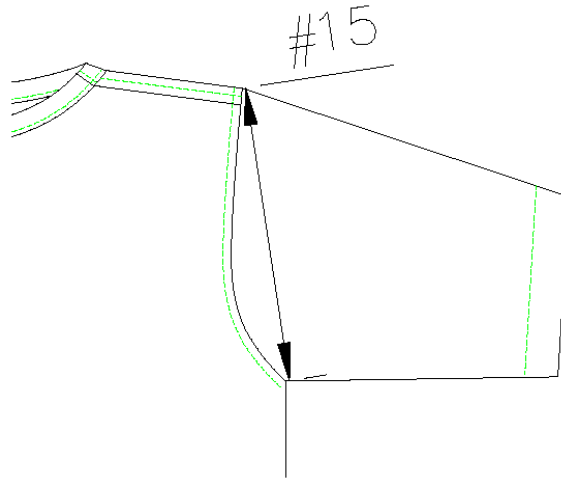

16. NECK CIRCUMFERENCE

- Undo all buttons and lay garment flat so that the inside of the garment is facing you.
- Measure from center of button to farthest end of buttonhole along inside of collar.

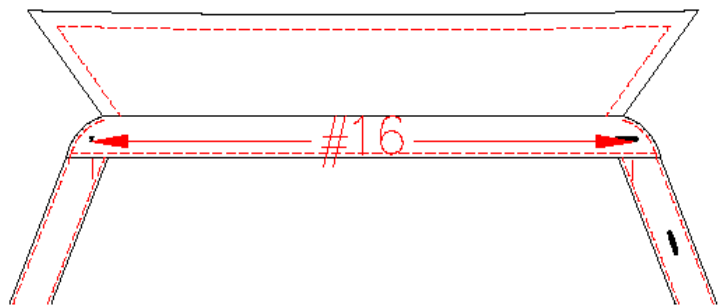

17. NECK WIDTH

- Lay garment flat.
- Measure straight, from high point shoulder to high point shoulder at the base of the collar or neck trim.

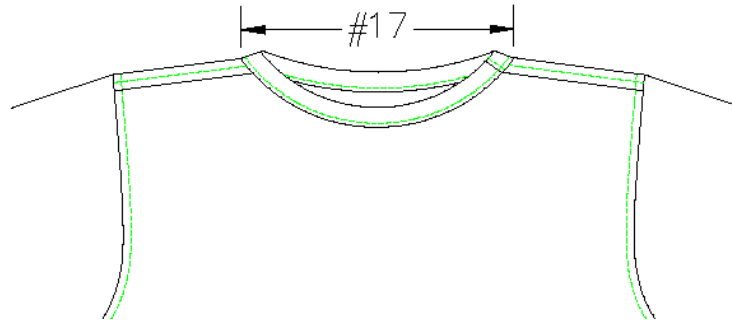

18. FRONT NECK DEPTH

- Lay garment flat with front facing you.
- Place a ruler straight across at high point shoulder points.
- From center point, measure straight down to neck seam (base of collar, stand or neck trim) at the center front.
- On V-neck garments with button closure, measure to the center of the top button.

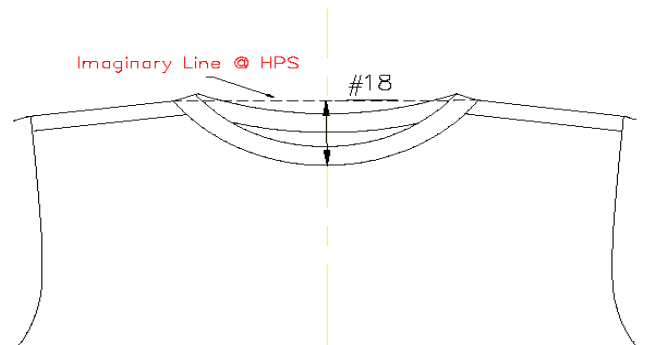

19. BACK NECK DEPTH

- Lay garment with back facing you.
- Place a ruler straight across at high point shoulder points.
- From center point, measure straight down to neck seam (base of collar, stand or neck trim) at the center back.

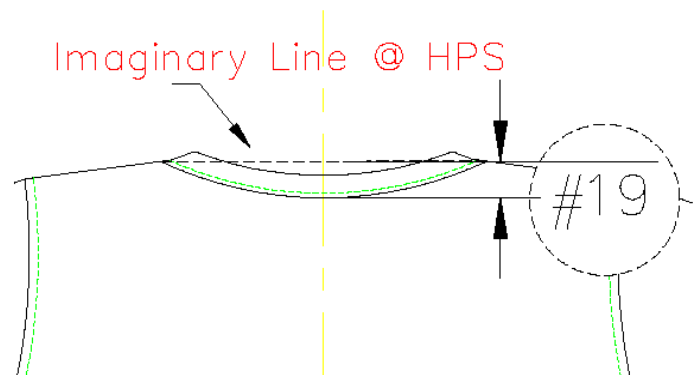

20. COLLAR LENGTH POINT TO POINT

- Undo all buttons and lay collar flat so that the inside of the garment is facing you.
- Measure along the outer collar edge from collar point to collar point.

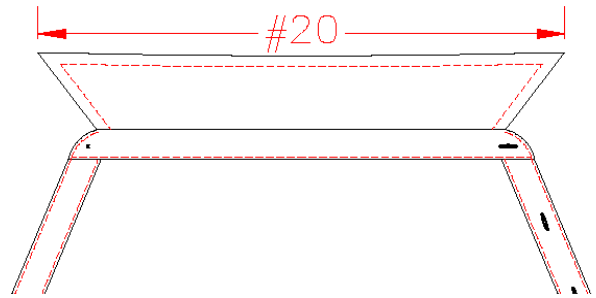

21. MINIMUM NECK STRETCH

- Lay garment flat with rib or collar edges even.
- Stretch neck without breaking stitches and measure across the neck opening where the rib or collar meets the neck seam.

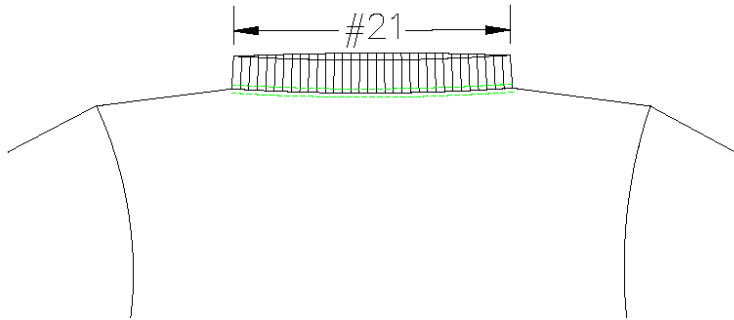

22. CENTER BACK TO WAIST PLACEMENT

- Measure from center of back neck seam to waistline of garment.

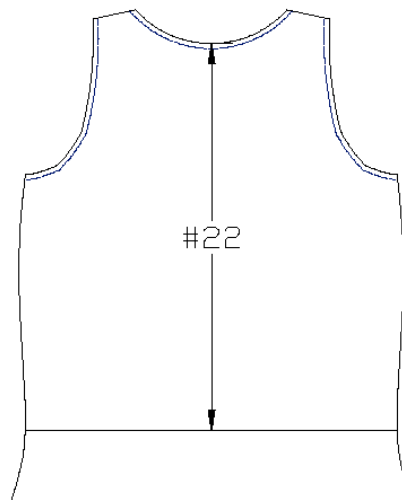

23. BODY LENGTH FROM HIGH POINT SHOULDER

- Measure from high point shoulder down the body to the bottom of the garment.

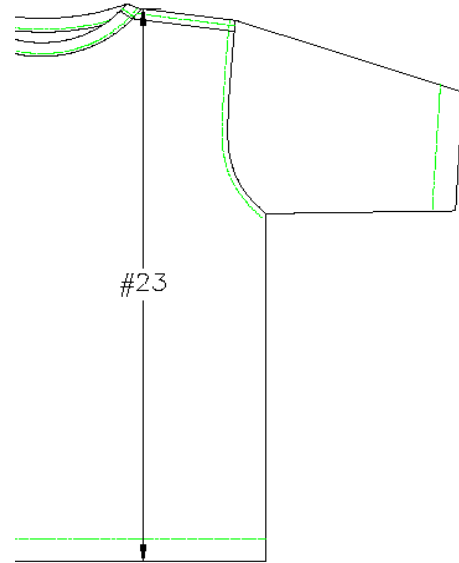

24. CENTER BACK LENGTH

- Measure from waistband (if no waistband, measure from top) or back neck seam to the bottom of the hem.

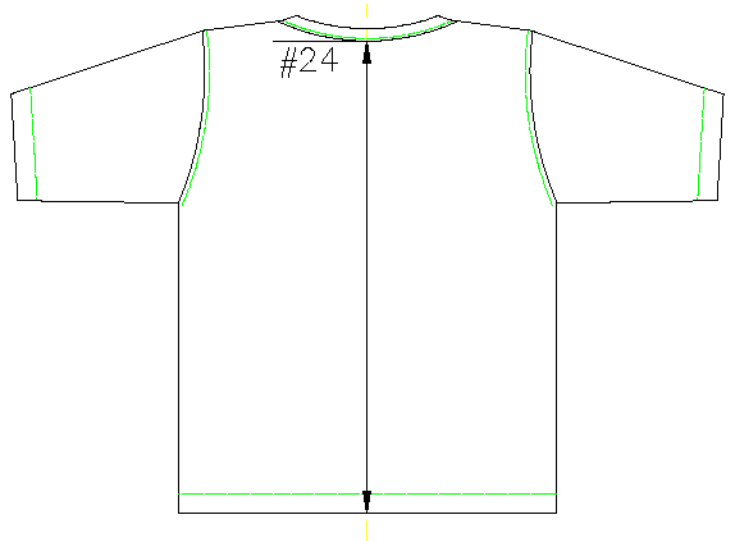

25. SLEEVE LENGTH

A. GARMENTS WITH SET-IN SLEEVES (3 POINT MEASUREMENT)

- With back of garment facing you, measure from center back to shoulder seam; pivot and measure to cuff or end of sleeve following fold.

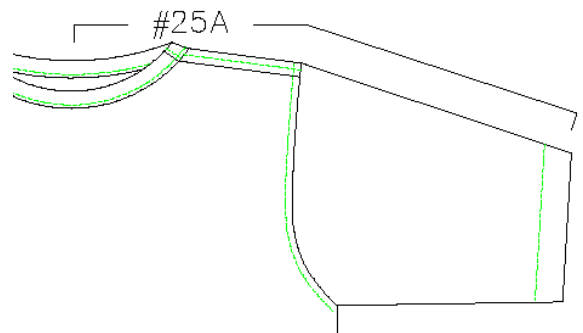

B. GARMENTS WITHOUT SET-IN SLEEVES (2 POINT MEASUREMENT-RAGLANS, SADDLE SHOULDER)

- With back of garment facing you, measure straight from center back neck to cuff or end of sleeve.

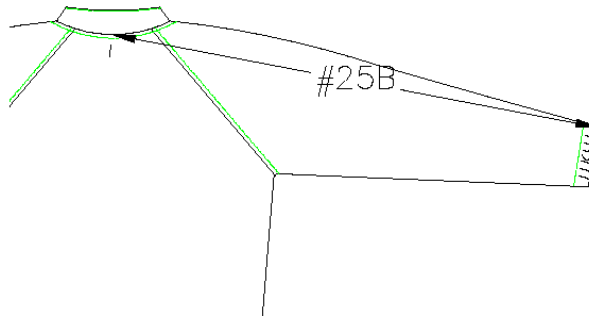

26. MUSCLE*

- Measure 1" down from armhole at underarm seam.
- Measure straight across sleeve parallel to the sleeve opening.

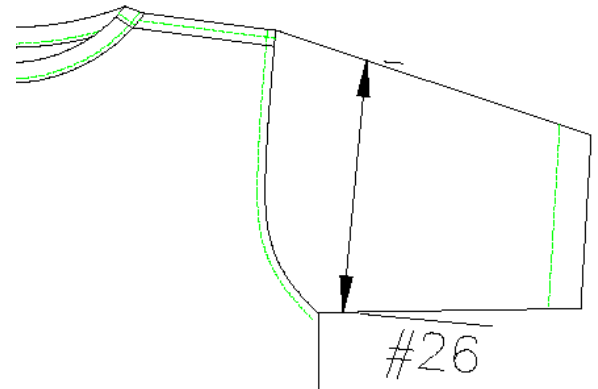

27. SLEEVE OPENING*

- Measure straight across finished edge of sleeve.

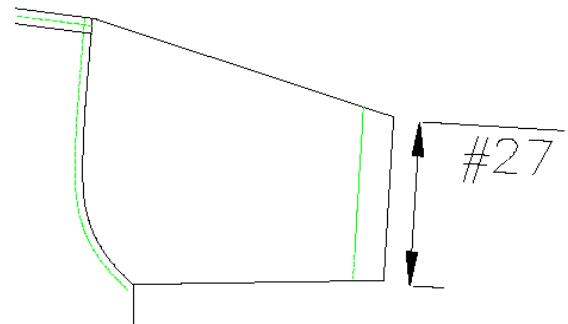

**Measurement is doubled.*

FABRIC AND GARMENT TESTING

TravelSmith requires all TravelSmith branded garments to be lab tested. It is the factory/vendor's responsibility to test production fabric and garments to ensure all products meet all the ASTM and AATCC standards. TravelSmith has a testing program with Bureau Veritas. All testing standards are given in our Bureau Veritas Test Manual found at <http://ccsginc.com>. If you wish to use another testing lab, please get approval from the Vendor Compliance and Quality Control Manager. All test results should be reviewed and approved prior to cutting bulk fabric. Please notify TravelSmith immediately if there are any concerns about fabric quality or performance.

CPSIA

The Consumer Product Safety Improvement Act (CPSIA), which was enacted on August 14, 2008, imposes new requirements on a wide variety of products that are regulated by the U.S. Consumer Product Safety Commission (CPSC).

REGULATION SUMMARY:

- Section 14(a)(1) of the Consumer Product Safety Act, as recently amended by the CPSIA, requires a *General Certification of Conformity* “GCC” to be issued with respect to every product that is subject to any consumer product safety rule, ban, standard, or regulation enforced by the CPSC. This form can be downloaded from our vendor site <http://ccsginc.com/travel.htm>.
- The GCC is required for all import and domestic products subject to all applicable rules, bans, standards and regulations. Products without the required certificate cannot be imported or distributed in commerce in the United States.
- The GCC requirement is immediately applicable to products manufactured on or after November 12, 2008.
- TravelSmith expects ALL import & domestic vendors to meet the GCC requirement per the CPSC. The law applies to ALL applicable products and for ALL brands (National, Vendor, Market, No brands, etc.).
- Refer to website for CPSIA GCC requirements information www.cpsc.gov/about/cpsia/cpsia.html).
- Refer to website for CPSC Regulated Products list (www.cpsc.gov/businfo/reg.html).

PROCEDURE:

1. VENDORS PRODUCING TRAVELSMITH BRANDED PRODUCT:

TravelSmith has always held the expectation that TravelSmith vendors have an established, effective and compliant quality assurance and testing program that insures your manufactured products meet all U.S. safety & regulatory requirements as well as TravelSmith’s standards.

According to the regulations issued by the CPSIA, the GCC must be issued by the importer for imported products and by the manufacturer for domestic products. Vendors must ensure that the GCC is prepared accurately and consistently.

- ***If TravelSmith is the Importer of Record:*** the rough draft GCC is created by the vendor and agent ONLY after successful completion of all required TravelSmith testing; then the GCC is to be sent to the Vendor Compliance department at TravelSmith via fax (414) 921-5140 or email vendorweb@travelsmith.com for review, approval & issuance.
- ***If TravelSmith is NOT the Importer of Record **OR** the product is produced domestically:*** the GCC is created by the domestic distributor/vendor ONLY after successful completion of all required TravelSmith testing.

TRAVELSMITH TESTING REQUIREMENTS:

- Vendors to contact the TravelSmith 3rd Party Laboratory for panel testing. This should be noted on the test and to TravelSmith Sourcing by listing the TravelSmith item# and TravelSmith name for each applicable product.
- In regards to 16 CFR 1303 Lead in substrates and coatings, vendors must certify compliance to the 300ppm lead in substrates and 90 ppm lead in coatings beginning now.
- Vendors to keep on record certificate/statement of proper lead content from their finish suppliers for each batch of finish ordered. The vendors must maintain these records with GCC records for 5 years and must be available to TravelSmith within 24hrs of request.

IMMEDIATE VENDOR ACTIONS REQUIRED:

- ***Vendors to begin sending a GCC for all applicable product shipments that were manufactured on or after November 12, 2008.***
- Vendor to provide the GCC along with other required import shipping documents.
 - ***If TravelSmith is the Importer of Record:*** the vendor is responsible to provide the TravelSmith issued GCC in their shipping documents to TravelSmith's forwarder.
 - ***If TravelSmith is NOT the Importer of Record:*** the vendor is responsible to provide the GCC in their shipping documents for import.
- The vendor must maintain records of the GCC issued for 5 years. GCC must be available upon request to TravelSmith within 24 hours of request.

2. VENDOR PRODUCING NON-TRAVELSMITH BRANDED PRODUCT

(national brands, vendor brands, market brands, no brands, etc.)

TravelSmith has always held the expectation that NON-TravelSmith branded product vendors have an established, effective and compliant quality assurance and testing program that insures your products meet all U.S. safety & regulatory requirements as well as TravelSmith's standards.

IMMEDIATE VENDOR ACTIONS REQUIRED:

- Vendors to execute a GCC based on a reasonable testing program.
- Vendor to provide the GCC along with other required import shipping documents.
 - ***If TravelSmith is the Importer of Record;*** the vendor is held responsible to provide the GCC in their shipping documents to TravelSmith's forwarder.
 - ***If TravelSmith is NOT the Importer of Record;*** the vendor is held responsible to provide the GCC in their shipping documents for import.
- The vendor must maintain records of the GCCs issued for 5 years. GCC must be available upon request to TravelSmith within 24 hours of request.

PRODUCT LABELS

The TravelSmith logo is registered and required on all TravelSmith brand products. TravelSmith labeling requirements are in conformance with the Federal Trade Commission regulations. Labeling is an important part of the product identification. If products are found to be improperly labeled during our quality inspection process the shipment will be rejected.

MAIN LABELS AND SIZE TABS FOR WOMEN’S AND MEN’S

Men’s and women’s will use labels ordered from AZI only. The label styles are mitre fold and end fold. All garments will have a size tab with the country of origin under the alpha or numeric size. “Joint” garments (Men’s and Women’s similar styles) will use the “Mens” or “Womens” designation on top of the size tab. The size tab will be sewn to the bottom of the main label, centered.

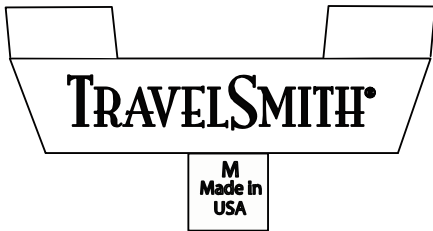

CONTACT INFORMATION

American Zabin International (AZI)
US Label contact:
Joe Hoenester
joe@aziusa.com
(949) 851-0883 ph
(949) 851-1421 fax

Hong Kong Label contact:
Pian Chim
pian_chim@zabin.com.hk
(852)3758 7000 ext. 166

CARE AND CONTENT LABELS

The care content label is printed and sourced by each vendor or factory. Each label will be printed on a white satin ribbon quality with black printing. Size should be 1” (2.5cm) wide by the length that is determined by care instructions.

In addition to the information on the label shown, this label can be used to give additional country of origin information, for example “Made in USA of Imported Fabric”.

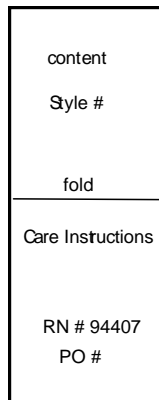

LABEL PLACEMENT

Read through the below placement suggestions. Please note: there will always be an exception to these rules. Please check with your merchant to confirm unusual placement of any label.

Main and Size Tab Labels

1. Mitre Fold – WL096471 - Use for Knit tops and dresses, woven tops with collars but without collar stands, knit and woven elastic waistband pants or skirts. Set at Center Back horizontal seam.
2. End Fold – WL096470 – Use for knit and woven jackets, woven shirts and dresses with collar stands, woven tunic tops, bottoms with waistbands, sweaters, outer wear pouches with outside logo, all sleepwear tops and bottoms.
3. Size Tab- WL096472 – Sew centered at the bottom of the main label.

Care Label Placement

1. Left side seam 3-4” up from finished hem or edge –Shirts, Jackets, Sweaters, Tunics. For Dresses, 5-6” up from finished edge in left side seam.
2. In waistband seam, to the wearer’s left of center back – pants, skirts, culottes, gauchos, capris, or shorts with waistbands or elastic waist.

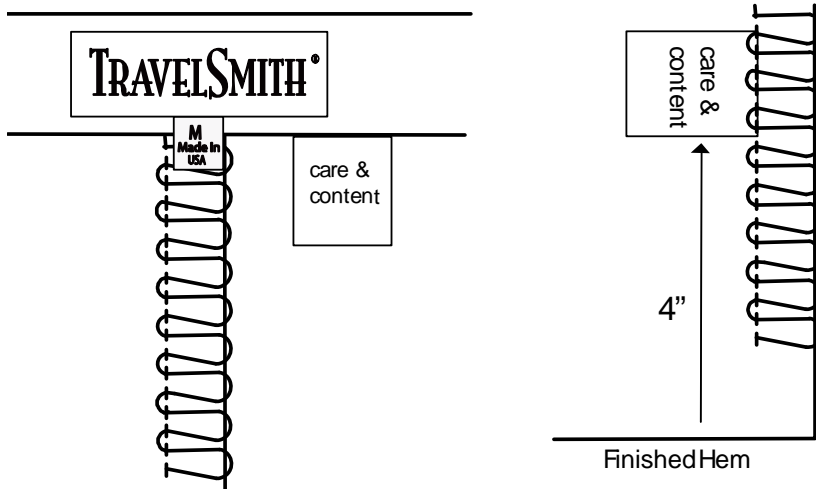

IV. PACKAGING AND PACKAGE LABELS

ITEM PACKAGING AND LABELING

APPAREL

The packaging for TravelSmith branded products is intended to protect the goods from soil or damage. Appropriate stabilizers are required to improve the product appearance during all phases of shipping, i.e. cardboard to retain shape of a shirt or collar bands to stabilize neck shape on banded collared shirts. Utilize the correct size logo polybag for products to eliminate excess movement or wrinkles.

Polybags may be obtained from:

Domestic Contact:
CAL SUPPLY
2855 Volpey Way
Union City, CA 94587
Phone: (800) 562-2625
Fax: (510) 429-0426

International Contact:
KAM WAI POLYETHYLENE BAG CO.
Flat I, 6/F, Block 1
Kingswin Ind Bldg., 32-50 Lei Muk Road,
Kwai Chung, N.T. / Hong Kong
Phone: (852) 2423-3545/2420-6709
Fax: (852) 8169-0802
Email: ada@kwnc.com.hk

Sizes available are:

<u>Size</u>	<u>Description</u>
12"	Bottom hanger box
17"	Garment polybag
21x4x4	Garment polybag 1000/cs 30# roll
14x19 - 3" flip	Garment polybag
12x15 - 3" flip	Garment polybag 1500/cs
16x23.75 - 2.5 flip	Garment polybag 500/cs

Another supplier may be used if prior approval is obtained from TravelSmith. Polybags must have the correct artwork and color. The TravelSmith Vendor Relations Coordinator must approve a polybag sample.

Packaging materials:

- All polybags (unless otherwise specified) must be a minimum film gauge of 1.25 mil and printed with the TravelSmith logo. Any polybag under 1.25 mil requires a suffocation safety-warning label.
- Polybags can be made of high clarity virgin or recycled resins. Low-density polyethylene, polypropylene and ethylene vinyl acetate is acceptable.
- All polybags must be sealed. The closure can be heat-sealed (bag must have air vent holes), folded and taped, or have self-sealing, reclosable adhesive strips.

ITEM LABELING CONTENTS

All merchandise must be individually labeled (affixed to the item or its packaging) with the following information:

- a. TravelSmith Item/Style # (from PO) and Vendor Item # (if applicable)
- b. TravelSmith Specific Color Name (if applicable)
- c. Style (if applicable)
- d. Size (if applicable). For Apparel, denote "Regular", "Petite", "Short", "Long".

Every item shipped to the TravelSmith Distribution Center must have the TravelSmith sku labeled on it. A sku includes the style number, the 3 digit alpha color code and the size code. An example would be 5566 BLK L. The vendor's sku is not required. If you are not certain what your TravelSmith sku is, check your purchase order, or ask your control buyer.

ITEM LABELING CHARACTERISTICS

All label fonts must be in Univers or Arial 12 or ¾ point.

The product type labels must meet the specified requirements:

- a. Locate polybag labels on the front lower right
- b. Locate suit/garment labels on top right
- c. Locate box labels on outside upper right
- d. Locate shoe box labels on lower right
- e. Recommended size is 1" x 2-5/8". Smaller sized labels must be approved by Vendor Relations Coordinator.

POLYBAG ITEM LABEL

List the style #, color code, and size as they appear on your PO; examples shown below.

The following is an example of a Women's Crimson size medium top:

32101 CRI M

The following is an example of a Women's black size 10 petite pant.

22156 BLK 10P

The following is an example of a Women's plus size blue 2X shirt.

20207 BLU 2X

The following is an example of a Men's Indigo Jean, size 36" waist by 32" inseam.

8507 IND 36W 32L

The following is an example of a Men's 42 long Khaki Blazer.

8855 KHA 42L

LUGGAGE AND TRAVEL ACCESSORIES

PACKAGING

All luggage or travel products must be packed in one of the following ways to prevent damage in our DC:

1. Ship-Along Packaging: ship alone cartons are for items that are too large in size to pack with other items. These products ship to the customer in the vendor packaging due to the limited availability of stock cartons in our distribution center. All ship alone items must be packaged individually so they can survive the rigors of small parcel (UPS, and USPS) shipping.

Reshipper cartons must be brown box cartons with a minimum case burst strength of 200lbs and minimum edge crush test of 32.5 pounds (see below). All reshipper cartons must be able to pass our 14 point drop test as outlined in our drop test procedures. Failure to pass this drop test will result in additional charges due to non-compliance and the costs associated with repackaging required to enable a passing result.

* The UCC-128 label on the outside of the carton provides sufficient item labeling. *

2. Individually boxed inside a master carton (each inner carton must contain only ONE unit)
3. Individually polybagged or shrink-wrapped in a master carton with other single bagged same items

POLYBAGGING

If you are polybagging your merchandise, we prefer you use our logo polybags if possible although it is not strictly required. If your item is too big to fit in one of our bags, or if you are shipping a non-exclusive item, you have permission to ship in a plain polybag.

ITEM LABEL

All items require a product label that includes the TravelSmith style number, and if appropriate, color/size:

12345 BLU

ITEM LABELING CHARACTERISTICS

1. All label fonts must be in Univers or Arial 12 point font.
2. Labels must use a permanent adhesive.
3. Locate polybag labels on the front lower right
4. Locate box labels on outside upper right
5. Recommended size is **1" x 2-5/8"**. Smaller sized labels must be approved by Vendor Compliance Manager.

CASE ATTRIBUTE REQUIREMENTS

GENERAL CAPABILITIES

Case sizes must conform to the following dimensions to be inducted on the inbound conveyor and to be stored in our reserve and active picking locations. The Vendor Relations Coordinator must approve any exceptions to the standard case size requirements.

STANDARD CASE SIZES:

24"(L) x 17"(W) x 8"(H)

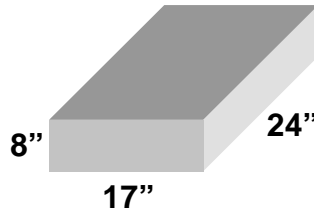

24"(L) x 17"(W) x 15"(H)

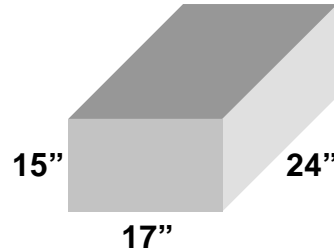

61cm(L) x 43cm(W) x 19cm(H)

61cm(L) x 43cm(W) x 38cm(H)

The above standard case sized must be utilized if the item fits within one of these cases. Any item that dictates a case size outside of the standard must fall within the following range:

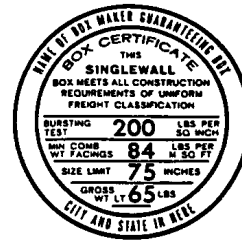
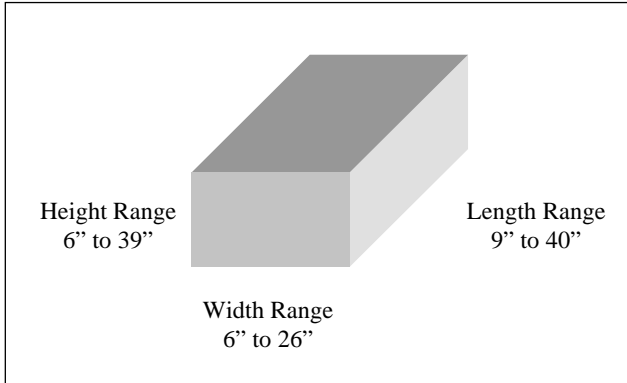

Inches can be converted to centimeters by multiplying the inch measurement by 2.54.

STANDARD CASE WEIGHTS:

The MINIMUM case weight is 2 lbs.

The MAXIMUM case weight is 50 lbs.

Case burst strength of 200 lbs. (91 kg) or greater.

Edge Crush Test (ECT) of 32.5 lbs. (15kg) is required.

Any type of corrugate is OK.

CASE PACKING

- Cases must contain only **ONE SKU** (style, color, size / ie 12345 Blu S)
- Cases **MUST NOT** be packed with multi-unit boxes or bagging.
- Separate different soft goods SKU's with tissue paper.
- If your shipment consists of one SKU in multiple cases, the quantities per case must be the same. Only one non-uniform quantity case per SKU, per shipment, is acceptable.
- Individual cases must contain items from only one Purchase Order.
- All items must be shipped against a valid Purchase Order.

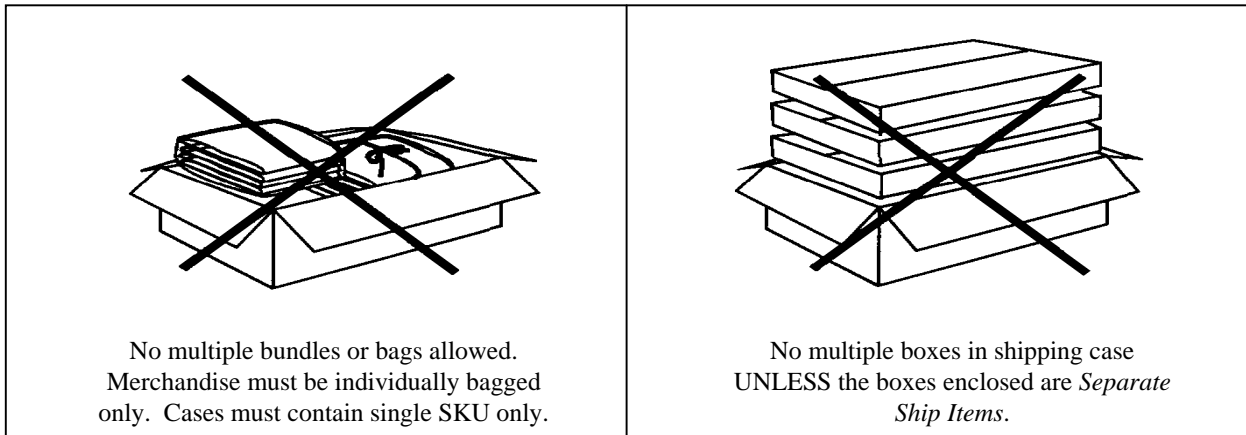

Note: A *Separate Ship Item* is an individually packaged item in a shippable box with dimensions that may exceed the above maximums.

These case packing requirements facilitate receiving and processing of the products. If you cannot conform to these requirements, please contact the TravelSmith Vendor Relations Coordinator prior to shipping.

CASE SEALING/PALLETIZING

TAPING AND SEALING CASES

Due to the large number of cases received at the Distribution Center, standardized case sealing simplifies inventory and quality inspections. Taping must not obscure any required case markings or labels. Below is the recommended sealing technique for the standard case:

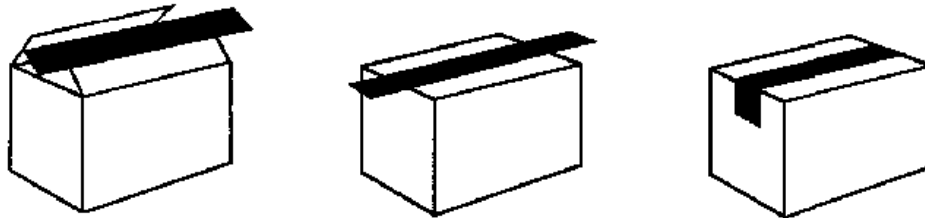

To minimize employee hazard and prevent damage to our material handling equipment, **do not secure cases with straps, bands, plastic or string** (except *Separate Ship Items*).

PALLETIZING:

- The required pallet size is 48" long x 40" wide (1.22m long x 1m wide).
- Use 4-way pallets.
- A pallet label, including the following information, must be on all 4 sides of EACH pallet:
 - Vendor Name from PO
 - Address
 - PO #
 - PRO #

-“PLEASE DO NOT BREAK DOWN SKIDS”

- d. Cartons on the pallet must not overhang pallet length or width.
- e. Maximum height of pallet 65” (1.65 meters) including cases and pallet.
- f. When palletizing multiple Purchase Orders, cases of the same PO should be on the same level of the pallet or on the same pallet. Shrink wrapping the cases of each PO is required.
- g. Cases of the same PO should be numbered “xx of xx” starting with “1 of xx”.
- h. OK to combine PO's on one pallet; just put 1 pallet label on all 4 sides
- i. Place cases on pallet so all case labels face outward as shown:

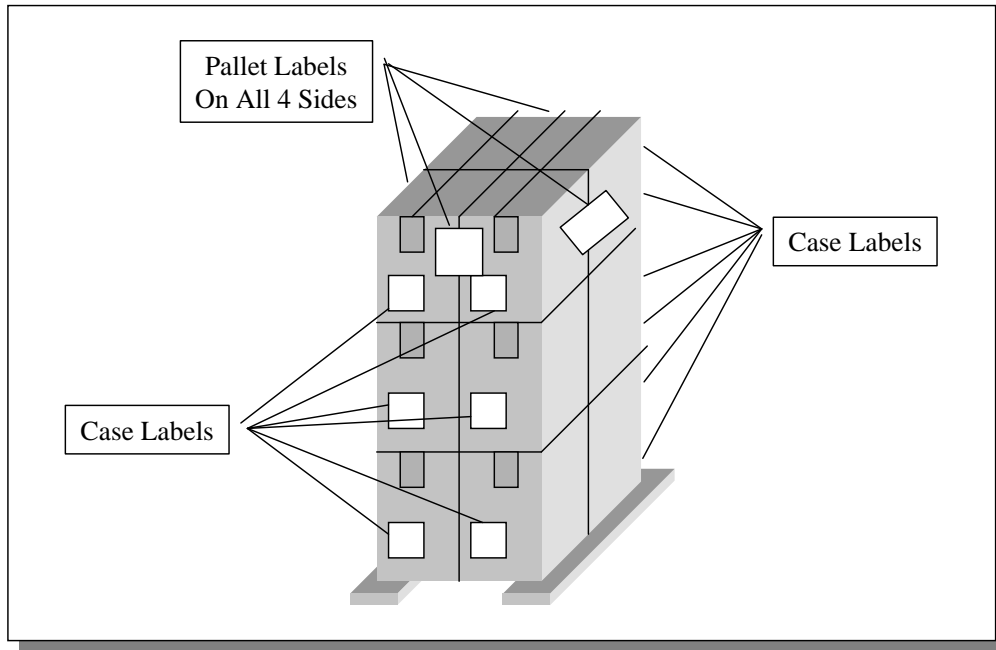

PLEASE CONTACT THE VENDOR COMPLIANCE MANAGER AT 415-798-3027 IF YOUR FACILITY IS NOT CAPABLE OF PALLETIZING SHIPMENTS. WE WON'T REFUSE YOUR SHIPMENT IF YOU CANNOT PALLETIZE, BUT THERE WILL BE A CHARGEBACK FOR THE ADD'L HANDLING REQUIRED. TYPICALLY, THE CARRIER WILL DELIVER PARTIALS AND/OR MISPLACE ONE OR MORE CARTONS.

V. FULFILLMENT

TravelSmith DOMESTIC VENDOR ROUTING GUIDE Effective 4-1-09 through 3-31-10

The following routing instructions apply to all ship to locations.

*Please refer to the purchase order for the correct ship to address.

OVERSIZE and EXCEPTION SHIPMENTS - ANY of the Following

Weight is greater than 2,500 pounds.

Shipment is less than 4 pounds per cubic foot and occupying 750 or more cubic feet.

Shipment is 1,500 or more cubic feet.

Shipment is 6 or more skids.

Any Air or Expedited Shipping Requests.

If your shipment meets ANY of Oversize or Exception Shipment characteristics please contact the Routing Center at Kingsgate Transportation for Custom Routing.

Please note that Kingsgate may route shipments via Yellow.

Please be sure to record the Routing Authorization Number on the Bill of Lading.

Routing Center Web Utility Address: <http://www.kingsgateextranet.com/ccsg>
Routing Center E-Mail Address: cornerstone@kingsgatetrans.com
Routing Center Phone Number: 800-336-3441 x1027

Standard Shipments

If Shipping From: **California All zips.**

Shipment Weight	Carrier Name	Carrier Phone Number	Carrier Website/E=Mail	Other Information
0 – 100 pounds	UPS	800-Pick-UPS	www.ups.com	Use UPS <u>Collect</u> Billing - Account # X03469
101- 750 pounds	Yellow	800-610-6500	www.yrc.com	Billing is Freight Collect
Over 750 pounds	Kingsgate	800-336-3441 x1027	http://www.kingsgateextranet.com/ccsg	Kingsgate may route shipments w/ Yellow.

If Shipping From: **New Jersey All zips, New York zips 10000 to 11999 and Pennsylvania zips 18900 to 19499.**

Shipment Weight	Carrier Name	Carrier Phone Number	Carrier Website/E=Mail	Other Information
0 – 100 pounds	UPS	800-Pick-UPS	www.ups.com	Use UPS <u>Collect</u> Billing - Account # X03469
101- 750 pounds	Yellow	800-610-6500	www.yrc.com	Billing is Freight Collect
Over 750 pounds	Kingsgate	800-336-3441 x1027	http://www.kingsgateextranet.com/ccsg	Kingsgate may route shipments w/ Yellow.

If Shipping From: **Any State or Zip Code NOT Listed Above.**

Shipment Weight	Carrier Name	Carrier Phone Number	Carrier Website/E=Mail	Other Information
0 – 100 pounds	UPS	800-Pick-UPS	www.ups.com	Use UPS <u>Collect</u> Billing - Account # X03469
101- 2,500 pounds	Yellow	800-610-6500	www.yrc.com	Billing is Freight Collect
Over 2,500 pounds	Kingsgate	800-336-3441 x1027	http://www.kingsgateextranet.com/ccsg	Kingsgate may route shipments w/ Yellow.

Bill of Lading Requirements

1. Bill of Lading must have ALL Purchase Order Numbers on it.
2. Carton and Skid Count must be listed on Bill of Lading. Carton count must match ASN.
3. Routing Authorization Number (if applicable) must be on Bill of Lading.
4. All full truckload shipments must have a seal placed on them with the seal number listed on the BOL.

Please refer to the vendor compliance manual for ASN, packaging, labeling and all other requirements.

Routing guide is subject to change.

For the most up to date routing guide and vendor compliance manual please go to our web site at:

<http://www.ccsqinc.com/>

Failure to follow these routing instructions will result in a charge back penalty.

Please see the vendor compliance manual for details.

The DC phone number to arrange delivery is (513) 603-1024.

BILL OF LADING NEEDS TO READ “FREIGHT COLLECT”

1. Bill of Lading MUST have all Purchase Order numbers on it. Example: “P.O. #12345”
2. Carton and Skid Count must be listed on Bill of Lading. Carton count must match ASN.
3. Routing Authorization Number (if applicable) must be on Bill of Lading.

4. Please write "Do Not Break Shrink Wrap" on the BOL and if possible on the label, skid or box.
5. ALL ORDERS MUST BE SHIPPED SECURELY ATTACHED TO A SKID.
6. Please indicate the "Freight Class" of product. If unsure, please contact the carrier for classification.
 - a. Apparel shipments must list one of the following National Motor Freight Classification item numbers on the Bill of Lading:

Clothing	#49880
Clothing Shipped on Hangers	#49880
Socks	#49940
Gloves or Mittens.....	#49910
Hats	#49880

All freight-collect Less-Than-Truckload and Truckload shipments should list the freight bill-to as:

TravelSmith Outfitters, c/o Cass Information Systems
 P.O. Box 6556
 Chelmsford, MA 01824-0942

MANDATORY: CONSOLIDATE SAME DAY /DESTINATION

All Merchandise to be shipped from a single shipping address to a single destination address on the same day must be combined onto a single Bill of Lading. Routing Guidelines should then be applied to the entire Shipment.

FREIGHT CHARGE PAID BY VENDOR

- a. TravelSmith would prefer that our vendors use one of our house carriers in order to minimize carrier congestion at our receiving dock. [Freight on merchandise invoices will not be paid- must ship collect per routing guide.](#)
- b. No C.O.D. shipments will be accepted.
- c. Airfreight will not be allowed under any circumstances without prior authorization!

At time of shipping, please make sure an Advanced Shipment Notification (ASN) has been sent via EDI, Vender Net, or Emailed Excel Spreadsheet. Faxed ASN's are not accepted. If you have any questions regarding your ASN, please call (513) 603-1023 or the Vendor Compliance Manager at (415) 884-1332.

****Deviations from these routing instructions that cause TravelSmith to incur additional costs will result in a chargeback of the entire freight plus an additional \$25.00 processing fee.****

USE OF INCORRECT CARRIER WILL RESULT IN SHIPMENT BEING CONSIDERED FOB DESTINATION, MAKING THE VENDOR LIABLE FOR ANY SHORTAGE OR DAMAGE THAT OCCURS IN TRANSIT.

IMPORT REQUIREMENTS

The United States Customs Service was created to administer the trade laws of the U.S. Government and to collect duties and taxes on shipments of goods and baggage.

DOCUMENTATION

Entries are required by the Customs Service to accommodate the paying of duties and taxes that are due and payable to the U.S. Government at the time of importation. Duties are assessed when the importing carrier arrives at the U.S. port of entry. To facilitate the entry of goods into the United States, U.S. Customs officials require documentation provided to secure their release. Documentation must be provided within 5 working days from the date the carrier arrives. To successfully meet these requirements, TravelSmith requests the following documentation:

- a. Carrier's certificate, original bill of lading, or airway bill properly consigned
- b. Signed commercial invoice and packing list
- c. Detailed description of item in English
- d. Declare value of item (vendor's selling price) stated in U.S. dollar value

- e. Other cost of item (freight, insurance, etc.), if applicable
 - f. Net quantity for each item
 - g. Gross weight in kilograms
 - h. Country of origin of the item
- a. Case Labeling/Markings: The ‘country of origin’ must be marked on the outside of the case. This can be on a label or directly on the cardboard.
 - b. Item Labels: each imported article to TravelSmith is required to be marked with the country of origin and fiber content and must appear in English. The markings are included on the sewn-in labels for textiles and securely affixed to hard goods.

SPECIFICATIONS SPECIFIC TO IMPORT VENDORS

- a. Packing slips must be ON and IN the lead case for each purchase order
(Ex. Cases of the same PO should be numbered “xx of xx” starting with “1 of xx”, 1=lead case).
- b. Bill of Lading (BOL) and PRO# are supplied by the import vendor’s freight forwarder.
- c. The carrier for an import vendor is their freight forwarder.
- d. The UCC-128 label bar code must meet the following specifications:
 - Minimum narrow element: .02” (.05cm)
 - Wide element: 1.0” (2.5cm)
 - Minimum Bar Height: 1.0” (2.5cm)
 - Maximum Pattern Length: 3.12” (7.9cm)
 - Overall Pattern Length: 3.52” (8.93)
- e. Cases must meet the following dimensions:
 - Minimum case weight is 2lbs. (.9kg)
 - Maximum case weight is 50lbs. (22.7kg)
- f. All items must be shipped against a valid Purchase Order.

TRAVELSMITH INTERNATIONAL VENDOR ROUTING GUIDE

Effective February 1, 2009

Consignee/Destination: TravelSmith, 8877 Union Centre Blvd, West Chester, OH 45069

Importer # 94-316433100

Shipments originating from any country:

<p><u>Dimensional Weight: 1 to 56 lbs (1 to 25 kilograms)</u> Carrier: UPS Terms: Collect – Account X03469 <i>Please enter Purchase Order Number in the Reference Field.</i></p>
--

Shipments originating from Canada or Mexico:

<p><u>Dimensional Weight: 57 lbs and Greater (>26 kg)</u> Carrier: Yellow Freight Terms: Freight Collect – No Account # Necessary <i>Please reference the Purchase Order Number on the BOL</i></p>

Shipments originating from any of the countries below with a shipment weight > than 26 kg

PHOENIX	EXPEDITORS
Country	Country

Austria	Taiwan	Qingdao, CN	Zhongshan, CN	Brazil		
Belgium	Chiwan, CN	Sanshan, CN	Philippines	Denmark	Portugal	
France	Dalian, CN	Shanghai, CN	Vietnam	Germany	Korea	
Hong Kong	Fuzhou, CN	Shekou, CN		Great Britain	Spain	
Indonesia	Guangzhou, CN	Shenzhen, CN		India	Turkey	
Poland	Huangpu, CN	Tianjin, CN		Israel		
Sweden	Jiangmen, CN	Xiamen, CN		Italy		
Switzerland	Nanghai, CN	Xingang, CN		Netherlands		
Sri Lanka	Nanjing, CN	Yantian, CN		Peru		
Indonesia	Ningbo, CN	Zhanjiang, CN				

Attn: China origin port/province shaded in gray

Attn: China origin port/province shaded in gray

Forwarder/ Broker: Phoenix International Terms: Freight Collect – No account # Req.	Forwarder/ Broker: Expeditors International Terms: Freight Collect–No account # Req.
Find your forwarder’s origin office/contact at: http://ccsginc.com/travelsmith.htm “click” (Routing Guide Contacts)	Find your forwarder’s origin office/contact at: http://ccsginc.com/travelsmith.htm “click” (Routing Guide Contacts)
Original <i>Customs paperwork</i> sent to -	
Phoenix International Attn: Lisa Talmage 855 IL Route 83 Bensenville, IL 60106-1219 Tel: (630) 274-7950 Ext - 17001	Expeditors International Attn: Michelle Redmon 2000 Connor Road, Suite 190 Hebron, KY 41048 Tel: (859) 282-9494

Copy of originals should be sent via email to esimborg@travelsmith.com OR mailed to Accounting Dept., TravelSmith Outfitters, 60 Leveroni Court, Novato, CA 94949

Please note that “Customs Paperwork” includes but is not limited to: Commercial Invoices, Packing list and original Bill of Lading (if applicable) plus any other customs required paperwork for specific commodities.

*** FOR VENDORS THAT SHIP INTERNATIONALLY, AND THE TERMS ARE FOB DOMESTIC, YOU MUST BREAK DOWN/DE-VAN YOUR SHIPMENT BEFORE CALLING FOR PICKUP. OUR APPROVED DOMESTIC CARRIERS ARE NOT EQUIPPED TO PICK UP FULL SHIPPING CONTAINERS.**

WOOD PACKAGING MATERIAL

On September 16, 2005, the U.S. Animal and Plant Health Inspection Service (AHPIS) will bring into effect their new regulations involving the importation of many types of wood packaging material such as pallets, crates, boxes, and dunnage.

Wood packaging material used in international trade will be required to be treated either by heat treatment or fumigation by use of methyl bromide. Such packaging material will be required to be marked as having undergone such treatment.

For additional information on the new regulation, requirements and certain exceptions to the requirements; such as, WPM entering the U.S. from Canada, please visit the AHPIS website directly at <http://www.aphis.usda.gov/>.

ADVANCED SHIPMENT NOTIFICATION STANDARDS

TravelSmith requires an Advance Shipment Notification (ASN) for all shipments to our distribution center location. An ASN is case detailed information pertaining to your shipment. We require a consolidated ASN with case level information, as a minimum, for every shipment. Pallet level information is acceptable however, and must correspond to the case level information. It will include the UCC-128 carton barcode numbers, the TravelSmith SKU's, and carton quantities you are shipping. It must be 100% accurate. A packing slip *may not* be substituted for an ASN.

“Quantity” refers to each's, not quantities of prepacks.

➔ The ASN must be received by our warehouse via email at least 24 hours prior to your shipment being received.

We offer three options to send the ASN that will accommodate any vendor:

VENDOR NET * **WE STRONGLY RECOMMEND THIS OPTION** *

Vendors not set up for EDI transmission have the alternative to use Vendor Net, a web-based supply chain collaboration program that is available for printing UCC-128 compliant labels and producing the associated ASN. You need internet access, Microsoft Word 2000 or better, a PC (not a Mac) and a printer for printing orders and carton labels. If you want more information regarding Vendor Net, please contact the Vendor Compliance manager at 415-798-3027. This program is free, is easy to use, and requires just 30 minutes for training and 30 days for set-up. Plus, you will greatly reduce the likelihood of chargebacks by using Vendor Net.

EDI

The ASN needs to be transmitted via Electronic Data Interchange (EDI) in accordance with ANSI X.12 standards. These standards define the EDI ASN 856 advanced shipping notice document.

Our EDI Coordinator will provide specific information. You must have an open PO to qualify for testing as well as the ability to generate UPC codes. The wait list is 11 months long, and testing takes 3 months. If you would like to proceed, please contact the TravelSmith Vendor Compliance manager at 415-798-3027.

EXCEL SPREADSHEET ASN

The third option is a free Excel macro spreadsheet, downloaded directly from our Vendor Compliance website: <http://ccsginc.com>.

Click on the TravelSmith Link, and when prompted for a username and password:

USERNAME: **travelvc**

PASSWORD: **tsmith2000**

Please note username and password are case sensitive and *must be lowercase*.

The spreadsheet contains instructions for filling out the appropriate information within. You need to have Excel 97 or better to access the spreadsheet.

1. Send all email addresses of those who might be emailing ASNs to jmcafee@travelsmith.com. Without this advance notice, your emails will be treated as spam and will be discarded without being opened.
2. ASN spreadsheets should be completed and emailed as an attachment to asn-tso@ccsginc.com, as well as copied to your inventory planner. Be sure you are using the most recent version of this spreadsheet, as older versions will not be accepted. It is advised that you visit our website every few months to ensure that the version you are using is the most current. In the subject line of the email, include the PO #(s) in the ASN.
3. Your ASN will be processed the day after it is received. A reply email is sent confirming that the ASN was received. * **If you do not receive a reply email, it means that we did not actually receive your ASN (treated as spam and discarded) and you will be charged for a late ASN.** *
4. *Receipt of the ASN is not a guarantee that the ASN is accurate. If your ASN is incorrect, you will receive a chargeback even though you sent the ASN 24 hours in advance. *

If you have not shipped to TravelSmith previously, please review our ASN procedures at least four weeks prior to the designated ship date on your purchase order.

**Use only ONE PO per ASN.
1 ASN cannot be spread across multiple shipments.**

See example of ASN format utilizing UCC-128 bar codes on next page.

ASN SPECIFIC CONTENTS

Your ASN must be 100% accurate. In order to maintain accuracy, the 'scan and pack' method of ship notice creation is recommended.

ASN notification, as shown on the following page, must include the following information:

- a. Vendor #, name, address, and contact name and phone # (must match PO exactly)
- b. PO #
- c. Date Shipped
- d. Expected delivery date
- e. Carrier
- f. Ship complete indication (Y/N)
- g. PRO # or Tracking #
- h. Total units shipped
- i. Total weight
- j. Total cartons shipped
- k. Case level information
- l. UCC-128 Case #
- m. TravelSmith SKU #
- n. Case quantity
- o. Item quantity

ASN CREATOR FORM:

To Download this form, please visit <http://ccsginc.com>

PACKING SLIP CAPABILITIES

All shipments must be accompanied by a packing slip. Labels affixed to the outside of the cases do not constitute a packing slip.

The number of Packing Slips required depends on the method of shipment:

TRUCK LINE/CONTAINER

- Packing slip may be attached to the Bill of Lading (BOL).
- OR
- One packing slip externally attached on LEAD case for EACH PO (or on a carton that is clearly marked "Packing Slip Here.")

UPS/ALL OTHERS

- One packing slip externally attached on EACH case. (necessary because UPS does not always deliver all the cartons on the same day)
-

PACKING SLIP SPECIFICS

Packing slip information (see format next page):

- | | |
|-------------------------------------|---|
| a. Vendor name, address, phone, fax | h. Vendor Item # |
| b. Bill To: TravelSmith + Address | i. TravelSmith Item # |
| c. Ship To: TravelSmith + Address | j. Item Description (Qty, Size & Color) |
| d. Carrier Used | k. Total # of Cases |
| e. Ship Date | l. Total # of Units |

- f. Purchase Order #
- g. Carrier PRO #

- m. Total # of Pallets
- n. Weight of Shipment

Import shipment packing slips should be ON AND IN the lead case for each PO.

Sample Packing List: (vendor may use other formats)

VENDOR NAME		(short or long is OK)			
Street Address					
City, State, Zip Code					
Phone Number					
Fax Number					
<u>PACKING LIST</u>					
BILL TO:			SHIP TO:		
TravelSmith			TravelSmith Distribution Center		
60 Leveroni Court			8877 Union Centre Blvd.		
Novato, CA 94949			West Chester, OH 45069		
CARRIER USED:		CARRIER PRO #:		SHIP DATE:	
PURCHASE ORDER #:					
QTY ORDERED	QTY BACKORDERED	QTY SHIPPED	TravelSmith ITEM #	VENDOR ITEM #	DESCRIPTION (SIZE, COLOR, STYLE)
TOTAL UNITS		TOTAL CARTONS		TOTAL PALLETS	
TOTAL WEIGHT					

EXTERNAL CASE LABELING

EXTERNAL CASE LABELING –UCC-128 SERIAL SHIPPING CONTAINER LABEL (SSCC-18)

The VICS Uniform Code Council 128 (UCC-128) standard case label is required. For more information, call (800) 543-8137 or www.uc-council.org. Individual Case Labels must be affixed to each shipped case.

- UCC 128 labels may be handwritten however, most handwritten labels typically have errors which result in chargebacks.

CASE LABEL SUPPLIER

Please contact ADI to obtain high quality, low cost labels:

Adaptive Data Interchange (ADI)
 93 West Franklin Street
 Centerville, OH 45459
 Ph (937) 436-2343
 Fax (937) 436-2344
 Email: <mailto:jgribler@adi-barcode.com>

ADI can send labels that are as detailed as you want or they can send labels that are partially filled out. Or use Avery labels #5168 4"x6" or thermal labels 3.75" x 5.5".

EXTERNAL CASE LABELING SPECIFIC CONTENTS

Example case label:

SHIP FROM: ABC 12 Main St. Novato CA 94949	SHIP TO: TravelSmith 8877 Union Center Blvd. West Chester, OH 45069 USA
Ship To Postal Code: (420) 45069 	Carrier Info: Pro #: B/L #:
Purchase Order #: 0000044908 Travel Smith Item #: 10056 Vendor Item #: (optional) Size: XL Color: WHT Desc: W KNIT TOP	Qty/Case: 6 Case # 8 of 12
(00) 0 9999182 000002006 1 (00) 0 9999182 000002006 1	

EXTERNAL CASE LABELING FOR VENDOR NET

Vendor Net labels print a little differently from a manual carton label; example:

FROM: Vendor Number	TO: TravelSmith Distribution Center 8777 Union Centre Blvd. West Chester, OH 45069
SHIP TO POSTAL CODE	Carrier Info: Use Routing Guide BOL: Sample
Purchase Order #: TSO 0000040011 TravelSmith Item #: 12345 BLK MP VENDOR ITEM#: PUG 969 Vendor Desc: W KNIT WRAP TOP Quantity: 12 Carton: 1 of 6	
SSCC # (00) 0 0 0003214 00000440 2 	

UCC-128 SHIPPING CASE LABEL DATA REQUIREMENTS:

- a. Vendor Shipping Information (address)
- b. “Ship-To” Information (from PO)
- c. PRO # (optional)
- d. Bill of Lading (BOL) # (optional)
- e. TravelSmith Purchase Order (PO) #
- f. TravelSmith Item/Style #
- g. Vendor Item # (optional)
- h. TravelSmith Item Description (Size & Color)
- i. Quantity per Case
- j. UCC 128 Symbology (Case Identification Bar Code)
- k. Case Count (i.e. “01 of 05”)
- l. Lot # (optional)

GENERAL INFORMATION:

- a. Shipping Case Label must appear on every case
- b. Recommended label dimensions:
English: 6”(H) x 4”(W)

Metric: 15 cm(H) x 10cm(W)

- c. Type must be at least 3/16" (or 10 pt)
- d. Case Labels MUST be applied to the lower left corner of *short side* of the carton
- e. PRO #'s may be requested in advance from issuing Shipping Company
- f. Low-reflective tape, if tape is used on the label

EXTERNAL CASE LABELING SPECIFIC CHARACTERISTICS

UCC 128 SYMBOLOGY EXPLANATION:

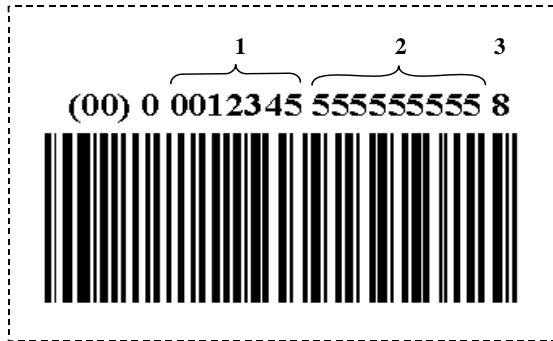

- 1) Vendor's UCC Number (or UPC preceded by a zero). Contact Vendor Relations Director if UCC numbers are not utilized
- 2) Unique Carton Identification Number (9 digits)
- 3) Check digit

NOTE: The Uniform Code Council has approved a standardized format for the UCC-128 Case Label. For more information, call (800) 543-8137 or www.uc-council.org.

This case label must have the UCC-128 bar code symbology.

The bar code must meet the following specifications:

- UCC Code 128 subset "C"
- Encoded Digits: twenty- (20) numeric
- Minimum Narrow Element: .02"
- Wide Element: 1.0"
- Minimum Bar Height: 1.0"
- **Maximum Barcode Length: 3.12"**
- Overall Length including Quiet Zones: 3.52"
- The carton label must be unique to each carton; duplicate carton numbers will result in a chargeback.

A UCC-128 bar code quality program must be in place that ensures ANSI A or B print quality (ANSI X3.182). Be sure to use "smudge-proof" labeling/ink and low-reflective tape (if tape is used to apply the label).

Case Label Placement Explanation and Guidelines:

Conveyables Labeling Guidelines

Challenges- Case must receive a usable scan and ride the conveyor securely. The scanner is pointed at the lower left-hand area of the approaching case. To ride securely, the center of gravity of the case must be as low and evenly balanced as possible.

Requirements- One UCC-128 case label must be placed on one of the smallest sides of the case. To do this, disregard what you may normally think is the height of the box. Find the two smallest measurements of the box. The smallest measurement will become your height and the next to the smallest measurement will be your width. Turn the box with this side facing you. Place the label upright, lower left-hand corner, 1 inch from the bottom and left edges of the case. If your height is smaller than 6 inches, you can wrap the top portion of the label over the top of the box. Case flaps should not effect label placement. However, do

not cross a flap with a UCC barcode.

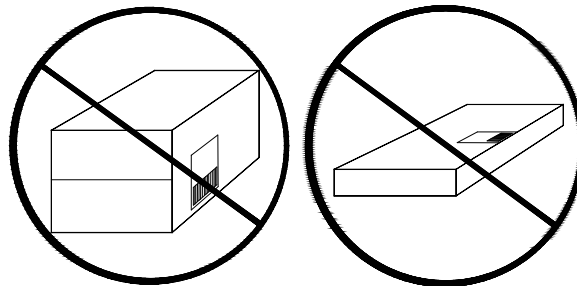
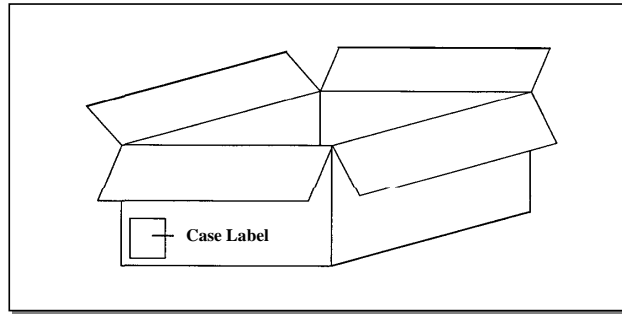
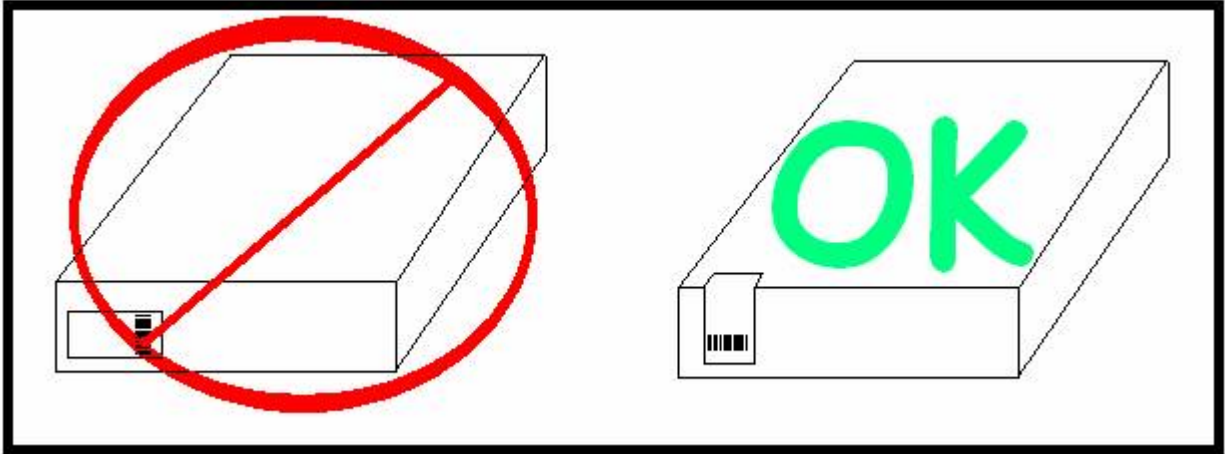

- *Failure to place the carton label in the correct location will result in a Vendor Chargeback.*

All of the above requirements when it comes to carton labeling, sku labeling, packaging, ASN's, shipping, etc can be completed by our third party partner for a fee.

Please contact **Larry Johnson** at ljohnson@kable.com.

Kable Packaging
4275 Thunderbird Lane
Fairfield, OH 45014
(Phone) 513-671-2800 ext 113 (Fax) 513-671-2830

VI. PRODUCT SAFETY

The Merchandising Department is responsible for ensuring compliance and minimizing product liability exposure. Your products must meet all federal and state product safety regulations, as well as any other applicable consumer protection statutes and regulations. To follow are some examples of Federal Trade Commission and Consumer Product Safety Commission federal regulations:

- Textile Fiber Products Identification Act
- Flammable Fabrics Act
- The Consumer Products Safety Act

VII. COMPLIANCE

Prior to your first shipment of goods to TravelSmith, we require that specific documents be read, signed and returned as acknowledgement to their contents. The document describes in detail the contractual method with which we conduct business with our vendors.

TERMS AND CONDITIONS OF PURCHASE

The terms and conditions of purchase are outlined on the TravelSmith purchase order. If you have any questions, please contact your Inventory Planner.

All purchase orders need to be reviewed by the vendor to confirm that ship dates, style number, colors, sizes, price, and credit terms are correct. An order confirmation needs to be sent to our office within five (5) business days after receipt of the purchase order. **Any discrepancies must be noted and communicated to the Inventory Planner immediately.**

TravelSmith expects all merchandise to be **shipped by the ship date requested on the purchase order.** All merchandise must be shipped on time. If your shipment is late, you are required to provide expedited shipping outlined in Section D below. You are also liable for one of the following penalties.

A 10% deduction on the total invoice value for the late purchase order.

OR

A \$10.00 deduction per unit backordered until the shipment is received and passes quality assurance at our distribution center.

DELIVERY OPERATIONS

A- Complete Shipments- each purchase order should be shipped complete as one delivery. In the event that a vendor is unable to ship an order complete by the specified ship date, a request for a partial shipment can be made by contacting the undersigned Inventory Planner prior to shipment.

Five (5) percent over/under requested purchase order per SKU may be accepted with advance notification to your Inventory Planner. Unauthorized variances are subject to chargeback penalties.

*Acceptance of partial shipments is at the discretion of the Inventory Planner. If partial shipments are approved, the Inventory Planner may require that certain sizes and colors be prioritized.

B- Overages- If a vendor wishes to ship over and above the quantities set forth in the purchase order, the undersigned Inventory Planner should be contacted before the goods ship. Quantities shipped over the amount in the purchase order will not be accepted without prior approval. Any such quantities will be deducted from the invoice, and a return authorization will be requested. The returned merchandise will be shipped freight collect.

C- Early Deliveries- Merchandise may not be shipped prior to the requested ship date without prior consent of the Inventory Planner. In the event that merchandise is shipped without prior consent, the Inventory Planner has authority to return the merchandise at the vendor's expense or receive the merchandise. If the

Inventory Planner elects to receive the merchandise early without prior consent, payment will be made according to the **original** expected receipt date, not the actual receipt date.

D- Late Deliveries- If an order is late, and will be shipped after the requested ship date, the Inventory Planner must be contacted immediately. A thorough explanation of the circumstances causing the delay should be communicated to the Inventory Planner via email. **Merchandise shipped after the requested ship date is subject to complete or partial cancellation by the Inventory Department.**

In addition, orders shipping late are subject to the following penalties:

- The vendor may be subject to paying the difference between air and sea freight charges when a late order designated to ship by sea must be expedited to air freight.
- The vendor may be required to cover the entire freight charges when an order scheduled for transport by air is late due to production delays.
- Domestic deliveries will be shipped via UPS 1 or 2 day (to be determined by the Inventory Planner) at the expense of the vendor.
- The vendor will be charged back at a rate of \$10.00/unit or 10% of the invoice for all merchandise that is back-ordered by our customers as a result of purchase orders shipping late from the agreed upon ship date.

TravelSmith expects all of our vendors to keep us informed of any shipping delays for any reason, including credit holds. Please contact our Accounts Payable and Inventory Planning Departments immediately if any potential credit problems arise.

➔ Merchandise not packed and shipped as specified in this manual will result in specified chargebacks.



Purchase Order

Purchase Order No.

Ship To: TravelSmith
8877 Union Centre Blvd.
West Chester, Ohio 45069

Bill To: TravelSmith -A/P
60 Leveroni Court Suite 1
Novato, CA 94949

Vendor #:

PO Date	Terms	Ship Via	F.O.B.	Ship Date
	Net	See Routing Guide		
	Days			

IMPORTANT:

- 1) Advance Ship Notice must be sent immediately upon shipment to 513-603-1481 or ash@ccsginc.com.
- 2) Cartons and contents must be labeled, packed and shipped according to the TS vendor compliance guidelines. For more details go to: <http://ccsginc.com> or call your planner.
- 3) All shipments are required to have both TravelSmith's PO number and TravelSmith's SKU number on all invoices, packing slips, and master cartons.
- 4) All bills of lading must show TravelSmith's PO number and the following statement: "Carrier - Please call 513-603-1024 to schedule delivery appointment".

Special Instructions:

TravelSmith SKU	Vendor Model No.	Description	Qty.	Unit Price	Ext Amount
Purchase Order Totals					

X

Signature indicates full acknowledgement of PO and agreement to order terms and conditions

PURCHASE ORDER TERMS AND CONDITIONS

By delivering the ordered goods or services, seller agrees to the specifications, terms, and conditions specified on the face and reverse of this document and any referenced documents (“Attachments”) seller’s additional or different terms and conditions, or any deletions, these terms and conditions can be varied only by a writing signed by the buyer. Seller shall not alter, add to, or otherwise affect these terms and conditions.

1. **PRICING:** Pricing is inclusive of applicable taxes, freight, packaging, insurance, handling and all other charges, whether similar or dissimilar, unless otherwise indicated on the face of this purchase order or in its Attachments. The prices quoted in this order shall remain in effect for the life of the catalog for which the items are being purchased. TravelSmith shall have the right to place additional orders at the price set forth in this order until notified in writing of any price change. All of the prices, terms, warranties, benefits granted by the Vendor for this purchase order, are equal or better than the terms being offered to any present commercial customer. If the Vendor during the term of this agreement shall enter into arrangements with any other company providing greater benefits or more favorable terms, this agreement shall automatically be deemed amended to provide the same terms to TravelSmith.
2. **STATUS AS INDEPENDENT CONTRACTOR:** The Seller is an independent contractor and while performing work on or off Buyer’s premises neither it nor any of its agency of employees shall be considered agents or employs of the Buyer
3. **DELIVERY:** TravelSmith expects all merchandise to be in our distribution center on the date required on the purchase order. If a vendor cannot ship the merchandise to TravelSmith within – days of the ship date noted on the purchase order, penalties and chargebacks may result as detailed in our vendor expectation letter. Any orders that are not delivered within 7 days of the date on the purchase order may be canceled by TravelSmith.
4. **INSPECTION AND ACCEPTANCE:** Notwithstanding any prior inspection or payments, all goods and services will be subject to final inspection and acceptance or rejection at Buyer’s place of business within a reasonable time after delivery. Buyer may reject all non-conforming goods and/or services. The Seller will furnish to TravelSmith only first quality items that conform to approved samples and specifications for color, style, fit, packaging, labeling, materials, design, and construction. Items that do not conform will be returned and charged back to the vendor. Buyer may choose, at Sellers risk and expense, to either hold non-conforming goods pending Seller’s instructions or return ship them to Seller’s address first shown on the face of this purchase order.
5. **WARRANTIES:** Seller warrants that all goods and services will conform to all written proposals and descriptions as well as any drawings, specifications, samples, or models furnished by buyer or furnished by seller and approved by Buyer. Seller warrants that all goods shall be merchantable and fit for their intended purposes and shall be new, not refurbished or reconditioned and all services shall be rendered in a good and workmanlike manner by skilled personnel.
6. **CHANGES:** Buyer may make changes to any services to be performed or any goods to be specially manufactured, but no change shall be effective, or shall Buyer be obligated to pay any increase in compensation as a result of change, unless Buyer issues a written order. Changes, which increase or decrease pricing shall be priced as mutually agreed to in writing or absent written agreement, shall be reasonably priced.
7. **PAYMENT:** Payment will be in accordance with the terms shown on the face of the order. All invoices shall clearly reference the shipment date, Purchase order number, and the TravelSmith Product number. When TravelSmith is billed for transportation charges, a copy of the freight bill will accompany the invoice. TravelSmith reserves the right to hold payment on orders shipped early until the requested delivery date, from which date the stated terms will apply.

8. **INDEMNITY:** SELLER SHALL DEFEND, INDEMNIFY, AND HOLD HARMLESS BUYER, AGAINST ALL DAMAGES, CLAIMS OR LIABILITIES AND EXPENSES (INCLUDING ATTORNEY'S FEES) ARISING OUT OF OR RESULTING IN ANYWAY FROM ANY DEFECT, WHETHER LATENT OR PATENT. IN THE GOODS OR SERVICES PURCHASED HEREUNDER OR FROM ANY ACT OR OMISSION OF SELLER, ITS AGENT OR EMPLOYEES, INDEPENDENT CONTRACTOR OR SUBCONTRACTOR. THIS INDEMNIFICATION SHALL BE IN ADDITION TO THE WARRANTY OR OTHER OBLIGATIONS OF SELLER AND SHALL APPLY WITHOUT REGARD TO WHETHER THE CLAIM, DAMAGE, LIABILITY, OR EXPENSE IS BASED ON BREACH OF WARRANTY, NEGLIGENCE, STRICT LIABILITY, OR ANY OTHER EQUITABLE THEORY. THIS INDEMNITY SHALL SURVIVE DELIVERY AND ACCEPTANCE OF GOODS OR SERVICES.
9. **INSURANCE:** Seller will maintain adequate insurance to cover any public liability, property damage, and automobile liability for any damage incurred in connection with Seller's performance of any work on or about Buyer's premises and shall maintain proper Worker's Compensation Insurance covering all employees performing this order.
10. **INTELLECTUAL PROPERTY INDEMNITY:** Seller warrants that all goods and services shall not infringe on any third party patent, copyright, trade secret, trade name, trademark or service mark, or other proprietary right. Seller shall at its own expense defend, indemnify, and hold Buyer harmless from any and all claims, liabilities, damages, and expenses (including attorneys fees actually incurred) by virtue of any claimed infringement of patents, copyrights, trade secrets, trade names, trademark service marks, or other proprietary right in connection with goods or services supplied.
11. **RISK OF LOSS:** Unless otherwise specified on the face of this purchase order, the goods ordered hereunder will be delivered on an FOB Buyer's place of business basis. Notwithstanding such delivery, Seller shall bear the risk of loss or damage to goods or services purchased hereunder in the event of and from the time Buyer gives notice of rejection of termination of this order.
12. **CONFIDENTIALITY:** The terms and existence of this purchase order and everything supplied in connection with it by Buyer shall be held in confidence by Seller. Seller shall not publicly announce or disclose this purchase order, or its contents, or use Buyer's name in any way including without limitation, a general or sample listing or Seller's customers, without Buyer's prior written consent. Any violation of this paragraph shall be deemed a material breach.
13. **LEGAL COMPLIANCE:** Seller warrants that all goods and services furnished shall comply with all applicable federal, state, and local laws, rules, regulations, and ordinances.
14. **EQUAL EMPLOYMENT OPPORTUNITY:** Seller agrees to comply with Executive Order 11246 as amended and all regulations and orders there under, all of which are incorporated by reference Seller will promptly furnish, upon Buyer's request, all certifications required there under.
15. **TERMINATION:** Buyer may terminate all or any portion of this order at any time by giving notice to Seller. In the event of any such termination, Buyer's liability shall be the lesser of (a) a reasonable price for raw materials, components, work in progress, and any finished units on hand: or (b) the contract price per finished unit, after giving effect to any discount Buyer would otherwise be entitled to. In the event of termination of any separate services specifically ordered, liability shall be the lesser of: (a) a reasonable price for the services rendered prior to termination: or (b) the contract price for the services. If any hourly or other time-based rate for services is specified in this purchase order, such rate shall be used in determining a reasonable price. Upon receipt of a termination notice, Seller shall, unless otherwise directed, cease work and follow Buyer's direction as to disposal of work in progress and finished goods.

GENERAL: Seller shall not assign this contract or any rights, nor delegate any duties. Any attempt to do so will be void. No waiver of any default by either party shall act as a waiver of a subsequent or different default. Section headings are for convenience only and shall have no legal or interpretive effect. This order shall be governed by and construed under the law of the State of California, except its choice of law-rules. The parties submit to the non-exclusive jurisdiction of the federal courts located in, and the state courts of, the State of California.

Chargeback Policy

As a supplier to TravelSmith, it is important that you comply with all of our product and packaging policies standards. Noncompliance with any of the procedures or standards will result in a chargeback, issued to you for the extra operational expense incurred by our Distribution Center. Charges will be determined for each violation and will be billed at \$50.00 per hour. There will be a \$100.00 fee added for each occurrence. You will be notified of any infraction and expected to correct the situation with future shipments.

If you fail to correct the occurrence for your next shipment, you will be billed \$200.00. The TravelSmith Accounting Department will be notified of the incident and a debit will be taken on your next invoice.

Note: Below is a quick reference chart of frequently incurred chargebacks. Any issue not in compliance with our Company Policies and Procedures outlined in this manual is subject to a chargeback.

ITEM	ASSESSMENT	2ND OFFENSE
Accurate & Complete Case Level ASN not received at Distribution Center 24 hours prior to receipt of shipment. ASN not sent via EDI, Vendor Net, emailed Excel Spreadsheet.	\$100 + \$50/hour to resolve/correct	\$200 + \$50/hour to resolve/correct
Purchase Order/ASN Discrepancies, duplicate UCC Case numbers used on ASN.	\$100 + \$50/hour to resolve/correct	\$200 + \$50/hour to resolve/correct
Minimum Case Markings not Present (TS SKU, PO #, QTY)	\$100 + \$50/hour to resolve/correct	\$200 + \$50/hour to resolve/correct
Inadequate UCC-128 case labels - including wrong location, non-compliant bar code, missing information.	\$100 + \$50/hour to resolve/correct	\$200 + \$50/hour to resolve/correct
Missing packing slip, packing slips not placed correctly, or missing case designation "Packing Slip Enclosed".	\$100/Purchase Order	\$200/Purchase Order
Shipping more than the number of PO's indicated on BOL. Failed to consolidate same day/ destination shipments on one BOL.	\$100/Bill of Lading	\$200/Bill of Lading
Not listing case numbers of a multiple case shipment (e.g. 1 of 4).	\$100/Purchase Order	\$200/Purchase Order
Use of unauthorized carrier.	\$100.00 plus difference in freight.	\$200.00 plus difference in freight.
No Delivery Appointment or Cases not Palletized	\$100/Shipment	\$200/Shipment
Unauthorized air freight.	100% of freight bill	100% of freight bill
Shipping incorrect freight class.	\$100 plus difference in freight cost	\$200 plus difference in freight cost
Receipt of merchandise not covered on the Purchase Order.	RTV – Vendor pays freight inbound and outbound.	RTV – Vendor pays freight inbound and outbound.
Merchandise received past cancel date may not be accepted.	RTV at Inventory Planner's discretion. Vendor pays freight inbound and outbound.	RTV at Inventory Planner's discretion. Vendor pays freight inbound and outbound.
Over shipment or duplicate shipments not authorized.	RTV at Inventory Planner's discretion. Vendor pays	RTV at Inventory Planner's discretion.

	freight inbound and outbound.	Vendor pays freight inbound and outbound.
Canceled Purchase Order will not be accepted.	RTV – Vendor pays freight inbound and outbound.	RTV – Vendor pays freight inbound and outbound.
Item labels missing or incorrect / Product incorrectly Packaged.	\$100 + \$50/hour to resolve/correct.	\$200 + \$50/hour to resolve/correct.
Early/late deliveries received without prior Inventory Planning approval.	Refer to Page VII. 1 of Vendor Manual	Refer to Page VII. 1 of Vendor Manual
Increased (up to 100%) quality inspections for QC problems discovered at TravelSmith Outfitters.	\$100 + cost per sku to resolve/correct. Possible RTV & freight costs for vendor resolution.	\$200 + cost per sku to resolve/correct. Possible RTV & freight costs for vendor resolution.
Multi-Sku Cases / Product Incorrectly Packed	\$5/case + labor & supply cost to re-pack & re-label.	\$5/case + labor & supply cost to re-pack & re-label.
Missing TOP samples	\$100 per PO	\$200 per PO
Banded Cartons / Carton Size outside of allowed range.	\$100 + \$50/hour to resolve/correct.	\$200 + \$50/hour to resolve/correct.
Style or color substitution without prior TravelSmith Outfitters approval.	Not accepted. Vendor pays freight inbound and outbound.	Not accepted. Vendor pays freight inbound and outbound.

RETURN TO VENDOR POLICY

TravelSmith reserves the right to return to the vendor all merchandise that has been rejected in our quality assurance inspection process that is not in compliance with our packaging, labeling, product specifications or quality standards. This policy also applies to customer returns with manufacturing defects.

If your company requires an authorization number for us to return product to you, an Inventory Planning Representative will contact you for an authorization number.

IF AN AUTHORIZATION NUMBER IS NOT RECEIVED WITHIN 30 CALENDAR DAYS, TRAVELSMITH WILL LIQUIDATE THE MERCHANDISE. YOUR ACCOUNT WILL BE DEBITED FOR THE COST OF THE LIQUIDATED MERCHANDISE.

VENDOR PARTNERSHIP SOCIAL RESPONSIBILITY GUIDELINES

TravelSmith is committed to the responsibilities of corporate citizenship in both the local and wider communities in which we do business. TravelSmith is concerned about human rights and we expect that our vendors share our ethical concerns. The following standards are used to select our vendors and we expect compliance with these standards by our contractors, subcontractors and suppliers.

LEGAL REQUIREMENTS

TravelSmith expects all of its partners to comply with the applicable laws and regulations of the United States and those of the respective country of manufacture or exportation. All products must be accurately labeled and clearly identified as to their country of origin.

HEALTH AND SAFETY REQUIREMENTS

TravelSmith requires its partners to provide a safe and healthy work environment that complies with local laws. The work environment must include adequate facilities and protections from exposure to hazardous conditions or materials.

EMPLOYMENT PRACTICES

TravelSmith respects cultural differences and believes that people are entitled to equal opportunity employment. We believe that people should be employed based on their abilities, rather than their personal characteristics or beliefs. TravelSmith pursues business partners who do not discriminate and who demonstrate respect for the dignity of all people.

FAIR WAGES

TravelSmith expects its partners to ensure that wages paid for a standard working week shall meet at least legal or industry minimum standards and shall always be sufficient to meet basic needs of personnel and to provide some discretionary income. Our vendors should offer benefits and work conditions that are consistent with local industry standards. We also expect them to comply with all applicable wage and hour laws, rules and regulations; including those related to overtime.

FREEDOM OF ASSOCIATION

TravelSmith expects its partners to recognize and respect the right of employees to freedom of association and collective bargaining. Our partners shall allow union organizers free access to employees and shall recognize the union of the employee's choice.

CHILD LABOR

TravelSmith will only do business with vendors who do not use child labor to manufacture product. TravelSmith will not use vendors that use labor performed by children, persons under the age of 14, that prevents legally required school attendance and/or that is performed under conditions hazardous to the physical and mental health of the child. TravelSmith supports legitimate workplace apprenticeship education programs for younger persons.

PRISON OR FORCED LABOR

TravelSmith will not conduct business with vendors who utilize prison, indentured or forced labor in the manufacture of its products. The use of corporal punishment or other forms of mental or physical coercion is unacceptable.

ENVIRONMENTAL STANDARDS

TravelSmith seeks partners who demonstrate a regard for the environment and who comply with local environmental laws. TravelSmith actively seeks partners who show a commitment to advanced environmental practices and to preserving the earth's natural resources.

DOCUMENTATION AND INSPECTION

TravelSmith intends to monitor compliance with our guidelines and to perform on-site evaluations of our vendors' facilities. TravelSmith may terminate its relationship with any partner found to be in violation of the Vendor Partnership Guidelines.

VIII. APPENDIX

DEFINITIONS

ADVANCE SHIP NOTICE – ASN

Pre-receipt information consisting of Purchase Order numbers and case contents by SKU.

BILL OF LADING – BOL

The legal document tendered to the carrier by the vendor/shipper at the time of pick-up.

CASE

A word used to refer to boxes of in-bound merchandise.

ELECTRONIC DATA INTERCHANGE – EDI

A means of sharing information electronically between business entities.

VENDOR NET-

A Web based program in which the vendor can transmit ASNs to the DC, print UCC-128 Labels, and print TravelSmith Purchase Orders. Basic requirements include web access, Microsoft Word 2000, and a printer.

ITEM

A word used interchangeably with physical product, referring to an individual unit.

LEAD CASE

Case #’1 of xx”. There is a lead case for every P.O. and Packing Slip. Lead case contains a packing slip inside the case and attached to the outside of the case.

PACKING SLIP

Interchangeable with Packing List. Document containing case level information by P.O. by shipment.

PRO NUMBER

A carrier's tracking number for a shipment to a particular ship destination.

RN# (Registered Identification Number)

It is a number issued by the Federal Trade Commission to U.S. businesses that manufacture, import, distribute, or sell products covered by the Textile, Wool, and Fur Acts.

SKU

Stock keeping unit. Is used to identify merchandise at the item, color and size level.

Example: Men's white oxford cloth shirt in medium:

Style 12345 (men's oxford cloth shirt)

Color WHT (white)

Size 1534 (neck/sleeve length)

STYLE

Used to identify a category of merchandise with the same item, color and size characteristics.

Example: Style 1234 all colors all sizes.

UNIFORM CODE COUNCIL – UCC

Establishes and promotes multi-industry standards for product identification and related electronic communication.

UNIVERSAL PRODUCT CODE – UPC

A twelve-digit ID Number used to uniquely identify companies and their products.